



GROUPE SEFMAT

RIPACK®

USER'S GUIDE

RIPACK 2000



PROTECTION BY EXCELLENCE

WWW.RIPACK.COM

RIPACK 2000

HAND-HELD PROPANE-FIRED HEAT-APPLIANCE INTENDED FOR PLASTIC FILM SHRINKING

GUARANTEE.....	3
WARNINGS	4
START-UP	8
EXAMPLES OF USE	10
MAINTENANCE.....	13
SPARE PARTS.....	18

GUARANTEE

Each RIPACK 2000 appliance is carefully manufactured from materials of outstanding quality. All the RIPACK component parts are subjected to a stringent control before the appliance is assembled and tested. For all maintenance and replacement of parts, please contact a RIPACK products distributor.

This appliance must be used with the original hose and pressure relief valve.

RIPACK GUARANTEES:

1. TOTAL GUARANTEE against any faulty manufacture on a new appliance that has not been subjected to any dismantling or modification, used in accordance with this guide, and not having been subjected to extended usage. The total guarantee covers the exchange only of any recognized defective part(s).
2. OPERATIONAL GUARANTEE of one year, provided that:
 - The appliance has been used in accordance with this guide;
 - The appliance has not suffered from any dismantling other than those provided for in this guide;
 - The geometry of the appliance is intact (e.g. no deformation of the body of the appliance, of the protective bars, or of the leading edges of the combustion nozzle, no crossed threads, etc...).

This guarantee does not apply to the following wear and tear parts:

- igniter
- ignition wire
- Hose

Any replacement part must be an original RIPACK part. The manufacturer declines any and all liability and any claim in recourse in the event of noncompliance with the preceding instructions and provisions.

The Company SEFMAT cannot be held liable for accidents caused to people or property due to an inaccurate use and/or usage beyond the scope of the instructions hereby. In the case of dispute, jurisdiction lies solely with the Courts of Bordeaux, France. No other jurisdiction is accepted.

The use or the resale of the RIPACK 2000 implies the total acceptance of above conditions.

FOR ANY CLAIM UNDER THE GUARANTEE, PLEASE ENCLOSE THE COPY OF THE INVOICE FROM YOUR SUPPLIER.

WARNINGS

TO BE READ CAREFULLY PRIOR TO ANY INITIAL USE

This appliance is intended **exclusively** for professional use and for plastic film shrinking.

It is essential that users of the RIPACK 2000 heat-gun make themselves familiar with this guide in full and that they be trained in the applications for its use.

This guide is to be kept for future reference.

In operation, this appliance produces a flame. Do not point it towards yourself, towards other people or living beings, or at the gas cylinder and hose, or at combustible materials.

Do not use the appliance for the application of plastic film on materials, products or liquids likely to catch fire spontaneously, whether loose or packed and in the storage areas of the said products or in premises where smoking is forbidden for safety reasons.

Do not use the appliance to shrink plastic film on flooring in combustible material (wood, plastic, etc...).

For each prolonged shutdown of the appliance, close the gas cylinder tap.

Be sure to keep the area in use clean and free from all debris (wood, paper, and other inflammable materials).

For all inside professional sites works, the gas cylinder shall be set on an independent and easy to move trolley.

As all gas-fired appliances, this appliance consumes air and produces combustion gases with CO² and CO. Exposure to the latter is fatal in high concentrations. Ensure adequate ventilation when using the appliance according to the duration of use of the appliance (see "TECHNICAL DATA").

Never work in a basement.

This device is intended to be installed and operated in accordance with the standard for the storage and handling of liquefied petroleum gases NFPA85.

Prior to any use, observe the requirements for the use of liquid gases.

CAUTION!

In operation, the appliance has a danger zone ahead of the burner extending to a distance of 3'6" (Table A).

The operator's attention is drawn to the fact that in this danger zone there is a possible risk of burns for living beings and/or fire to property.

It is strongly recommended to wear gloves when using the appliance and to avoid wearing nylon or similar inflammable clothing.

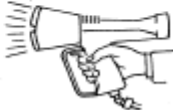
Table A: Distances and Temperatures			
0,90 m / 3 Ft	0,60 m / 2 Ft	0,30 m / 1 Ft	
100°C / 212°F	230°C / 446°F	400°C / 752°F	

This appliance is specifically designed for plastic film shrinking implementation. If the appliance is used beyond the scope of this user's guide, this will be only under the users' sole liability and after verifying that the product implements withstand heating by open flame. In all circumstances it is obligatory to refer to the recommendations of the manufacturer of the product processed and to local, federal or national legislation on the use of open flame appliances.

For safe use of the appliance, it is essential and obligatory to observe the warnings above and the instructions provided by the manufacturer of the materials processed. The distances of use, the times of exposure and the adjustment of the appliance, with respect to the various materials processed, all depend on the manufacturer's instructions of these materials.

CE MARKING

The RIPACK 2000 appliance can be stamped with **GS**, short for "Geprüfte Sicherheit" (verified safety), by virtue of its **DVGW approval** under number DG-2218AO0726 (93e054) and its compliance with the following standards:

- DIN EN 731 (Aug. 1981) and VP 103 (Dec. 1986) as a whole, and:
- DIN 3535 part 1 (seals), DIN 30 661 (sealing means), DIN 4815 part 2 (flexible hose), DIN 4811 (pressure relief valve), DIN 8542 and DIN 4816 (connections), DIN EN 731 (flame safety), for its main components.

The appliance is also in **compliance with the NF-E 65-140 standard** covering "portable LPG appliances for the shrinking of heat-shrink films".

On the other hand, the RIPACK 2000 cannot carry the CE sign, for the following reasons:

1. *"all industrial appliances are excluded from the field of application"* (directive 90/396/CE on gas appliances);
2. the RIPACK 2000, like all gas-fired shrink guns, **is not considered to be a machine**, as: *"the mobile part is actuated solely by human force"* (directive 98/37/CE on the safety of machines).

Consequently, and although the **RIPACK 2000 complies with the essential requirements of the European directive**, IT IS FORBIDDEN TO PUT THE CE MARKING ON THIS TYPE OF APPLIANCE (directive 93/68/CE of 22.07.93).

Contact your dealer for further details!

The RIPACK 2000 is a propane aero-gas blowpipe working on the high speed induced atmospheric air principle (drawing B).

Ignition is operated by a piezo igniter the effect of which is simultaneous to gas opening controlled by the trigger, sole control component.

The RIPACK 2000 is a reliable gun equipped with several **safety devices**. It meets all the existing standards in the majority of countries.

- Its original and patented design ensures combustion without heating of the burner (**cold nozzle**).
- A **safety valve** cuts off the gas supply in the event of the hose being cut or torn away.
- A dead-man device automatically cuts off the gas supply to the burner when the trigger is released, thus **immediately stopping** heating. Under no circumstances should this dead-man device be blocked in the open position by any means whatsoever.
- A **trigger guard** prevents any accidental start-up. Ensure that it is kept in place to maintain its function.

APPLIANCE RUNNING ON PROPANE GAS - TECHNICAL DATA:

Operating pressure: (PSI)	21	to	50
Consumption (lbs/h)	4.5		8.3
Power (kW)	27		55
CO Vol %	0.17		0.0075
CO/CO ²	0.13		0.037
CO ² Vol %	1.80		2.80
Aspirated air (cfm)			30

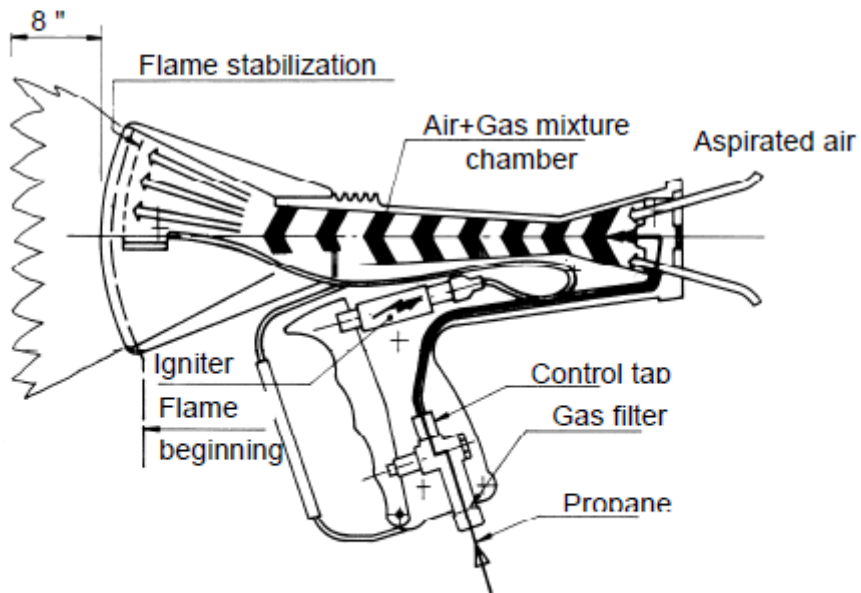

START-UP

Prior to start-up, it is necessary and obligatory to read the preceding warnings and to ensure that the manufacturer of the materials involved has not advised against the use of the appliance.

The RIPACK 2000 operates on vaporized propane gas contained in cylinders of varying sizes.

Use the largest size cylinder possible.

A propane gas cylinder is to be used standing upright with the tap uppermost.

NEVER LAY THE CYLINDER DOWN (drawing C).

DO NOT USE cylinders releasing propane gas in the liquid phase, mainly intended for the carburetion of vehicles (fork lift trucks or other applications).

ALWAYS connect and disconnect the cylinder away from any naked flame or point of ignition.

For all inside professional sites works, the gas cylinder shall be set on an independent and easy to move trolley.

1. Before connecting the pressure relief valve to the gas cylinder, ensure that the seal 1 is properly fitted for the system using this principle. In all other cases, ensure that the connection valve faces are clean (drawing D).
2. Connect one end of the hose to the outlet 2 of the pressure relief valve (drawing D) and the other end to the gun with swivel connection. Lock the connections with the spanner provided.
3. Open the gas cylinder tap.
4. Push the knob 3 **SIDWAYS** for at least 3 seconds to balance the pressure between the relief valve and the hose (drawing D).

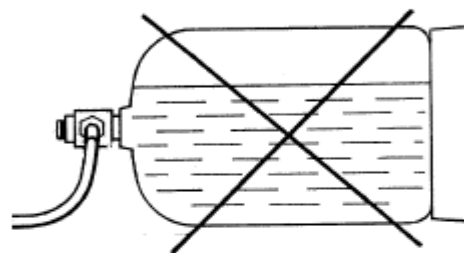
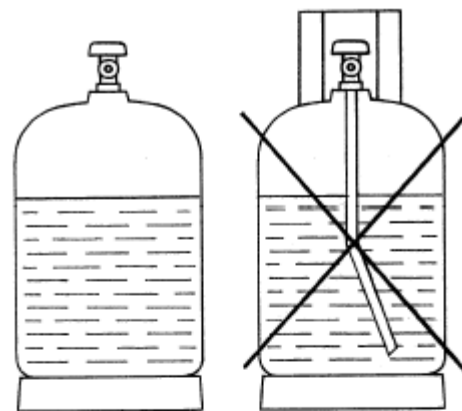

- C -



- D -

SEALING: ensure there are no leaks on the **screwed parts** (cylinder, hose and gun connections) with a bubble spray or with soapy water.

5. CAUTION! Ignition of the shrink gun:
proceed SLOWLY and in TWO STAGES:

- 1° Partially push the trigger for 1 second:
⇒ The gas mixture is forced up to the nozzle.
- 2° Pull the trigger all the way:
⇒ The igniter is actuated, the ignition is completed.

6. Adjust the flame according to the work to be performed, with the knurled knob 4 on the regulator, turning gently in the appropriate direction (+ or -) (drawing E).



- E -

The relief valve automatically cuts off the gas supply when the pressure drops below the minimum threshold required for proper operation. This indicates:

- either that the cylinder is practically empty (leaving only a few minutes of combustion with a very reduced flame): change the cylinder;
- or a drop in the temperature of the cylinder after intensive use (frosting). In this case, change the cylinder momentarily or wait for the pressure to return to normal, particularly when working outdoors (30°F and below).

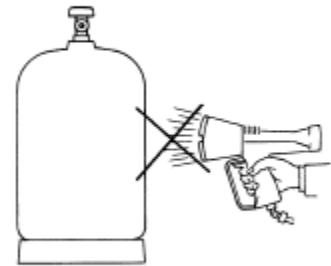

- F -

**NEVER HEAT A GAS CYLINDER WITH A FLAME (drawing F).
ALWAYS SHUT OFF CYLINDER TAP WHEN WORK IS FINISHED.**

Film shrinking of palletized loads

Ask your film supplier for recommendations on implementation.

The pallet must be raised so that the four corner blocks are free, to enable the film to be shrunk under the pallet and to provide the greatest possible cohesion between the pallet and its load (drawing G).

An accessory is available in the RIPACK range to hold the raised pallets: the CALPACK (consult your dealer).

Slip the shrinkable cover over the pallet. Its perimeter should be roughly 5% greater than the perimeter of the pallet, and it should be long enough to allow shrinking under the pallet.

Ignite your RIPACK 2000 according to the instructions in the section "Start-Up".

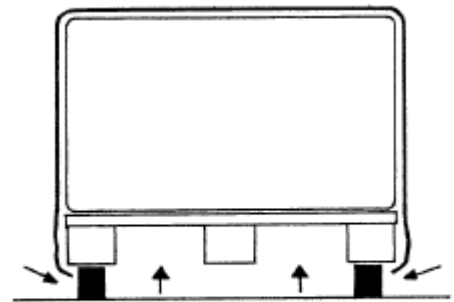

- G -

RECOMMENDATIONS FOR SHRINKING

(failing any specific recommendations from the film manufacturer):

Stand at least 30 centimeters (1 ft) from the film and start shrinking at the lower part on all four sides for shrinking to be completed first under the pallet. Ensure that the hot air is directed perpendicularly to the sides of the pallet (drawing H).

Apply heat in a continuous movement, at a constant rate.

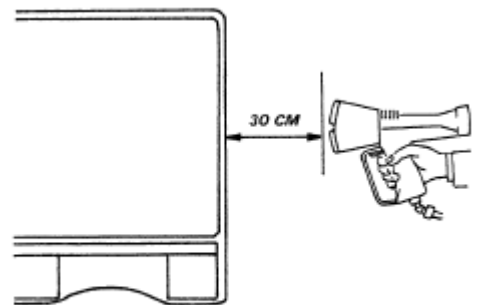

- H -

NEVER REMAIN IN A FIXED POSITION

As the reactions of films differ, observe the reaction of the film and adjust speed and/or distance accordingly.

The power of the RIPACK 2000 can also be adjusted by means of its adjustable pressure relief valve according to the different types of film.

Once the bottom of the pallet has been shrunk, continue on each side, sweeping the entire width of the side from the bottom upwards (drawing J).

Once the 4 sides have been completed, shrink the top by directing the hot air on the top of the pallet.

Caution: As the side shrinking already stretches the film, less heat must be applied to avoid damaging the cover (drawing K).

By its design, the shrinkable film will continue to shrink even once the heat has been turned off, for a period that depends on its quality, thickness and type of load covered. It is recommended to wait until the cover is cold and taut before moving the pallet.

After cooling and prior to storage, always check the integrity of the cover and of the products that have been shrink-wrapped (drawing L).

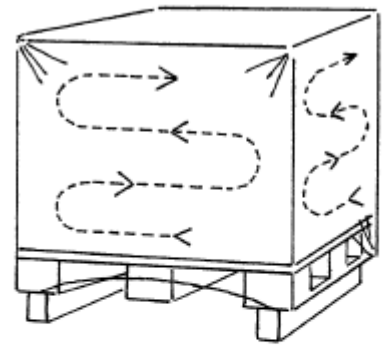

- J -

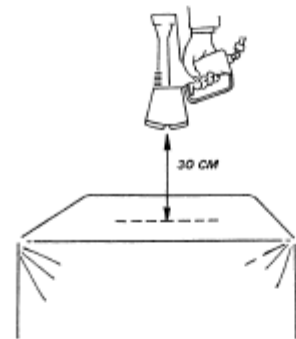

- K -

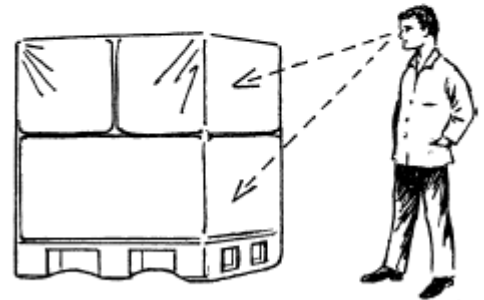

- L -

KEEP A STRICT SUPERVISION DURING AT LEAST 2 HOURS AFTER SHRINK OPERATION

Bundling

All kinds of items that do not fall within the configuration of a pallet can also be wrapped with a flat film, providing an overlap of at least 1 Ft is left for self-sealing (drawing M).

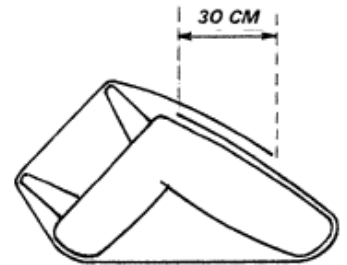

- M -

Heat the film in a continuous sweeping movement, pressing down on the overlap with a spatula to weld the two parts of the film together (drawing N).

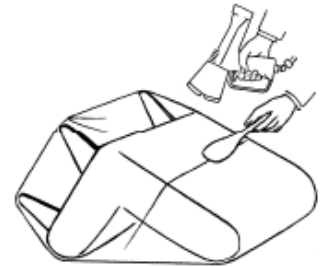

- N -

Once sealing has been completed, shrink the film, holding the appliance at a distance of at least 30 cm (1 ft) according to the recommendations for heat shrinking.

NOTE: The burner may be used vertically or horizontally for ease of operation (drawing P):

Unscrew the wing nut.

Turn the nozzle into the required position.

Retighten the wing nut.



- P -

Checking the safety devices:

Depending on the workload and for an appliance used daily:

- At least EVERY WEEK, check that the safety device against hose breakage (incorporated in the pressure relief valve) is working properly, as follows:
 - Go outside, away from any source of ignition, sparks and any burning object.
 - Pressurize the appliance. With the spanner provided, release the nut connecting the hose to the gun handle, and unscrew completely. The gas should turn off.
- EVERY DAY before starting work, check that the dead-man device is working properly, as follows:
 - away from any application, proceed as indicated in paragraph 5 of the section "Start-Up" and immediately release the trigger. The burner should immediately go out.
- AFTER ANY SERVICING that required dismantling of the appliance, check that the protection device against accidental ignition (trigger guard) is properly positioned, as follows:
 - pressurize the appliance and check by pressing it on an obstacle-free surface that it is impossible in any position to ignite the appliance, without pressing the trigger.

In the event of any failure of one or more of the safety systems thus checked, consult your RIPACK dealer.

Hose checking:

- EVERY MONTH check that hose is in good condition on its whole length and at connections.

Original parts:

Each RIPACK 2000 appliance is manufactured with great care from top quality materials. The RIPACK components are stringently checked before the appliance is assembled and tested. For maintenance and replacement of parts, consult a RIPACK products distributor.

It is compulsory to use the ORIGINAL hose and pressure relief valve as delivered with this appliance.

All replacement parts must be of RIPACK origin. The manufacturer declines any liability and any recourse in the event of the above recommendations and instructions not being observed.

To get the best performance from your RIPACK 2000

PROBLEMS	CAUSES	REMEDIES
<ul style="list-style-type: none"> The burner fails to ignite or is difficult to ignite 	☞ Cylinder empty	✓ Check the presence of gas in the cylinder (change the cylinder if required).
	☞ Cylinder tap shut.	✓ Open the cylinder tap.
	☞ Pressure relief valve not primed.	✓ Prime the pressure relief valve.
	☞ Gun tap blocked.	✓ Contact your RIPACK dealer.
	☞ Fault in the opening of the gun tap.	✓ After pressurizing the gun as per steps 1 to 4, screw the screw 22 to bring it into contact with the tap piston, to take up any play caused by wear on the piston. Follow steps 5 and 6.
	☞ Jet blocked.	✓ Clear jet (refer to "Cleaning").
	☞ Poor contact or insulation.	✓ Check insulation of the faulty wire to the igniter (refer to "Dismantling").
	☞ Piezo igniter worn out.	✓ Change the igniter (refer to "Dismantling")
<ul style="list-style-type: none"> The burner lacks power. 	☞ Electrode broken or burned out.	✓ Change the ignition wire (refer to "Dismantling")
	☞ Cylinder tap not fully open.	✓ Adjust accordingly.
	☞ Relief valve not in maximum position.	
	☞ Gas used is not propane.	✓ Use propane gas.
	☞ Gas cylinder capacity too small.	✓ Use a larger cylinder.
	☞ Low ambient temperature and intensive use.	✓ Alternate the use of several cylinders.
	☞ Jet blocked.	✓ Clean the jet (refer to "Cleaning").
	☞ Rubber hose kinked.	✓ Return to initial position.
☞ Gun gas tap filter clogged.	✓ Have the gun checked by your RIPACK distributor.	

<ul style="list-style-type: none"> • Weaker flame • Internal combustion • Heating of the nozzle 	<ul style="list-style-type: none"> ☞ Grid is blocked by air-borne particles (polluted atmosphere) 	<ul style="list-style-type: none"> ✓ Clean grid and venturi (refer to "Cleaning")
<ul style="list-style-type: none"> • Burner fails to go out 	<ul style="list-style-type: none"> ☞ Trigger stuck 	<ul style="list-style-type: none"> ✓ Have the gun checked by your RIPACK distributor
	<ul style="list-style-type: none"> ☞ Tap blocked 	

Dismantling - Reassembly – Cleaning (drawing Q)

DISMANTLING

1. Disconnect the hose from the gun. Open the gun chest and place the appliance on the foam with the ignition wire facing you.
2. Unscrew the screw 24 holding the electrode and remove the electrode from its housing. Unscrew the wing nut 29 and remove the combustion nozzle 1.
3. Unscrew the five screws fastening the handle and remove them from their housing. With the blade of a screwdriver, carefully separate the two halves of the handle. Lift the upper half of the handle 7b by roughly 10 mm holding the tap 6 in the lower half of the handle.
4. Pivot the upper half of the handle through roughly 40° to the right to release it from the upper guard support. Do not disengage the guard support from the lower half of the handle and from the front handle block. NEVER REMOVE THE TAP 6 OR THE GAS SUPPLY TUBE 4 FROM THE APPLIANCE. RIPACK DISTRIBUTORS MUST PERFORM THIS OPERATION.
5. Change the necessary parts (e.g.: ignition-wire 10 and piezo electric igniter 21).
6. Before reassembling the two halves of the handle, ensure that the ignitionwire 10 is properly fitted in the igniter 21 and then cover with the rubber cap 31.

REASSEMBLY

7. Position the ignition-wire 10 in the slot of the front handle block 13 by passing it between the plastic stop B and the body of the gun. Make a loop with the wire inside the lower half of the handle behind the gas tube.
8. Refit the igniter in its housing.
9. Check that the front handle block 13 holding the guard support 9 is located in its housing in the lower half of the handle 7a.
10. Check that trigger 8 and its brass pin 12 is located in its housing of the lower half of the handle and fit the trigger return spring 5 in its housing. Check that trigger stop A is set inside the lower half of the handle.
11. Replace the upper half of the handle 7b by following the same steps of dismantling in reverse (Step 4: presentation of the axis at 40°, place the guard support 9 in the cut-out and swivel to the left) and check that the various components are all in place (trigger pin, trigger, return spring, igniter, ignition wire and guard support).
12. Holding the unit together, bring the two halves of the handle together symmetrically, and tighten:
 - 1° the longest screw (30 mm) in position 25
 - 2° the 3 shortest screw (16 mm) in position 27
 - 3° the remaining screw (25 mm) in position 26
13. Tighten firmly, but without forcing.
14. Refit:
 - combustion nozzle 1 (after checking that the seal 23 on the body of the gun is in good condition and lubricate slightly before refitting the nozzle)
 - the electrode in its housing
 - the electrode screw 24
 - the wing nut 29 + washer 30
15. Check the operation of the gun according to the section "Start-Up".|

CLEANING – EVERY 6 MONTHS

- Remove the hose from the gun.

GRID CLEANING:

- Having dismantled the electrode from its housing and removed the wing nut 29 remove the combustion 1.
- Dip the nozzle for a few minutes in a dry petrol bath.
CHLORINATED DEGREASERS SHALL NOT BE USED.
- Rub the inside and outside of the grid with a soft or hard brush.
- Rinse once again and blow through from the outside and inside with a blast of compressed air until it is completely dry.

CLEANING OF THE VENTURI 2 (inner part of the gun body):

This must be done dry

- Rub the Venturi with a soft or hard brush.
- Clear with a blast of compressed air.
- Check that the seal 23 on the body of the gun is in good condition and lubricate slightly before refitting the burner.

CLEANING OF THE JET:

- Release and remove the nut 15 using the pipe wrench.
- Using an appropriate screwdriver, release the jet 16, remove and rinse in petrol. Clear with a blast of compressed air.
- After wiping the seal on the jet 16, refit the unit.
- Tighten the nut 15, without forcing.
- Check the operation of the gun according to the section "START-UP" and check with the gun in operation for gas leak at the nut 15 using a bubble spray or soapy water.

**FOR ANY AND ALL SERVICING ON THE GAS SYSTEM, PLEASE CONTACT YOUR
RIPACK DISTRIBUTOR.**

SPARE PARTS

Pos.	Description	Code
1	Combustion nozzle	233130
2	Body	233332
3	Jet holder	249021
4	Gas tube	150038
5	Trigger return spring	148044
6	Gas tap	248113
7a	Body half-handle right	133105
7b	Body half-handle left	133106
8	Trigger	133107
9+11	Handle guard + wire assembled	236060
10	Ignition wire	236022
12	Trigger pin	135045
13	Front handle block	132028
14	Electrode insulation ring	132015
15	Nut	145004
16	Jet	239006
20	Screw M4 x 8	152032
21	Igniter	131003
22	Screw M 8 x 6 (tap adjustment)	152041
23	O-ring in. \varnothing 28.24 x 2.62	140061
24	Screw TC 3 x 4	152001
25	Screw CHc M 4 x 30	152066
26	Screw CHc M 4 x 25	152065
27	Screw CHc M 4 x 16	152052
29	Wing-screw MA 5 x 8	152100
30	Flex washer \varnothing 5	148038
31	Rubber cap	133129
A	Trigger stop	
B	Plastic stop	
	Plastic chest grey	133131
	Wrench 19	133132
	Adjustable pressure regulator-double safety- 1.5-3.5 bar-NF/UNI/DIN/BS	134022/23/24/25
	Flat Seal for Regulator NF-UNI/DIN	140010/140020
	Swivel connector	148043
	Hose 8.0 M with connections (int. \varnothing 4)	250023

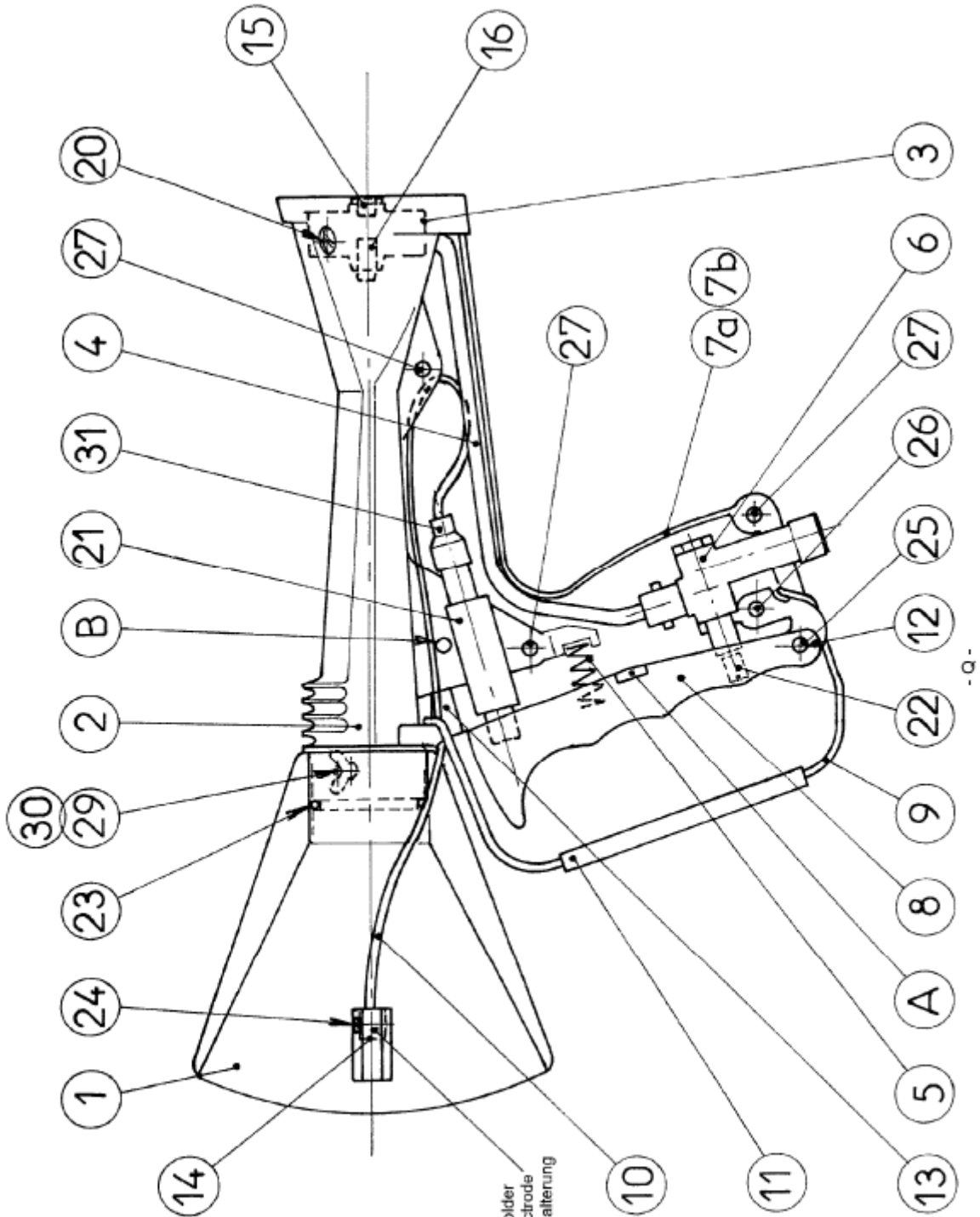

Electrode holder
 Support electrode
 Elektrodenhalterung

-a-