



GROUPE SEFMAT

**RIPACK®**

**USER'S GUIDE**

**RIPACK 2200**



**THE PROTECTION  
BY EXCELLENCE**

**WWW.RIPACK.COM**

**RIPACK 2200**

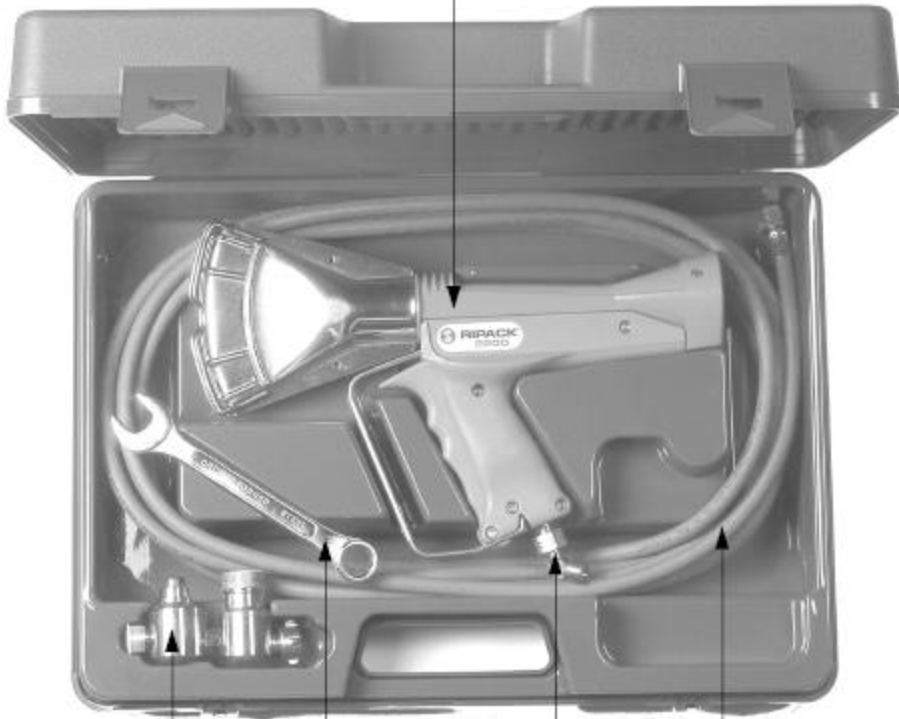

**SECURIPACK**  
Pressure  
regulator

Wrench

Swivel  
connector

8 m gas  
hose

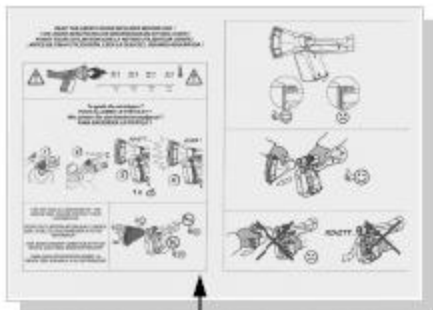

Memo



Warranty  
card



User's  
Guide

 GROUPE SEFMAT  
**RIPACK®**  
**2200**

HAND-HELD PROPANE-FIRED SHRINK GUN FOR  
SHRINK-WRAPPING PLASTIC FILMS

USER'S GUIDE

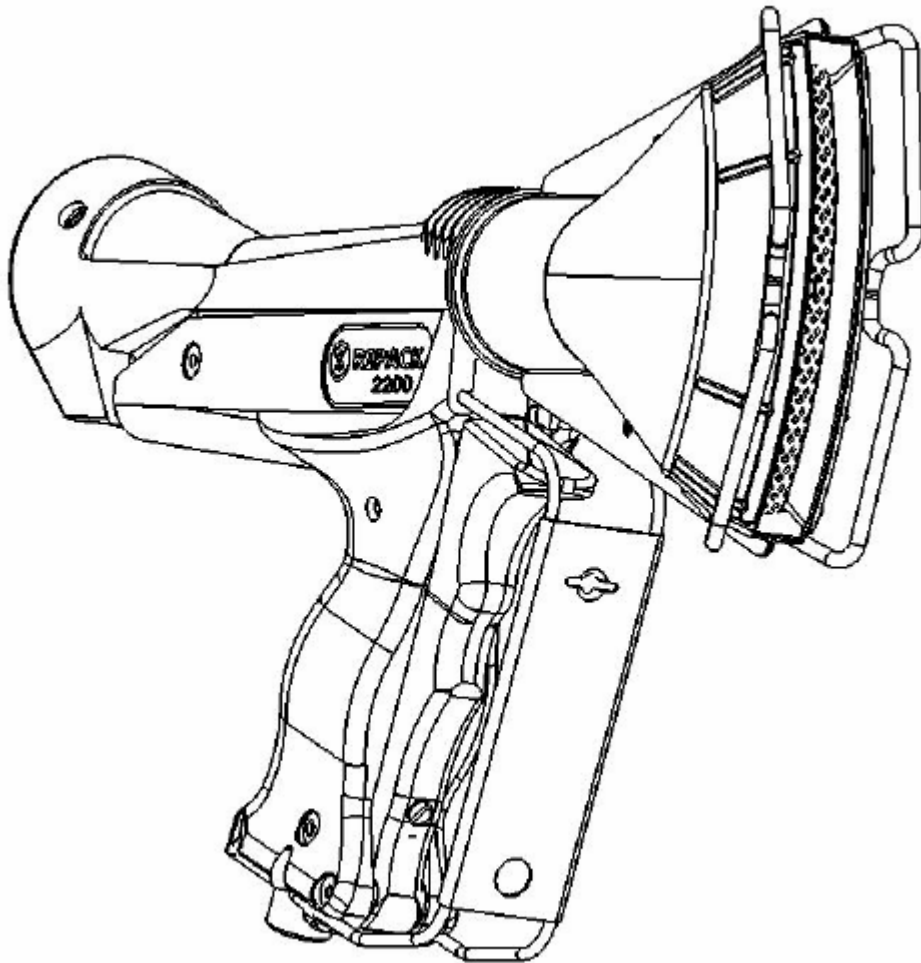

IMPORTANT NOTES.....	4
OPERATIONS .....	8
CONNECTIONS .....	9
SPARE PARTS.....	11
EXAMPLES OF USE .....	12
MAINTENANCE.....	15
WARRANTY.....	22
EXPLODED VIEW.....	23
SPARE PARTS LIST.....	24

## YOU MUST READ THESE INSTRUCTIONS BEFORE USING THE APPLIANCE.

<b>SAFETY PRECAUTIONS</b>
<b>1. Do not use this appliance in regulated zones where there is a specific risk of fire or explosion.</b>
<b>2. Limit a working zone that is large enough to ensure that the nozzle of the gun is always at a minimum distance of 1.5 m within this zone and indicate that access to this zone is forbidden for all other persons.</b>
<b>3. Always have a suitable fire extinguisher of an appropriate size within reach.</b>
<b>4. Wear gloves when using the appliance and never wear garments that are easily inflammable such as nylon or similar fabrics.</b>

This appliance is meant **exclusively** for professional use and for shrinking plastic films.

Users of the RIPACK 2200 shrink gun must read this user's guide completely and must be trained for the applications that require the use of this appliance.

This user's guide must be kept for future reference.

Do not use this appliance for shrinking plastic film on materials, substances, products or liquids that inflame spontaneously, either processed in bulk or packed, and do not use the appliance in the storage areas of these products or in spaces where it is explicitly forbidden to smoke for safety reasons.

Do not use this appliance for shrinking plastic film on a floor that is made of combustible material (wood, plastic, etc.).

Close the valve of the gas bottle when not in use for long periods of time.

Press the trigger to empty the gas hose and release the pressure.

Never heat a specific area continuously.

Keep the working zone clean and remove all waste (wood, paper, other inflammable materials).

For all work inside professional workshops, the gas bottle must be placed on a mobile trolley that can be manoeuvred easily.

**This appliance, like all other gas appliances, consumes air and produces combustion fumes that contain CO<sub>2</sub> and CO.**

**Exposure to high concentrations of the latter gas is lethal .**

**Make sure there is sufficient ventilation in accordance with the amount of time the appliance is used (see "Technical Characteristics") .**

**We recommend that the appliance be used in a room without specific pollution which has a minimum volume of 16 m<sup>3</sup> (fresh air flow: 48m<sup>3</sup> /h) .**

Never work in a basement.



Before using the appliance, make sure that you are conforming to the guidelines for using liquid gas.

In operation, this appliance produces a flame. Do not point the flame towards yourself, other persons or animals, towards the gas bottle or the hose, or towards inflammable materials.

In operation, the appliance creates a **danger zone up to 1.5 metres (5 feet)** in front of the fire nozzle.

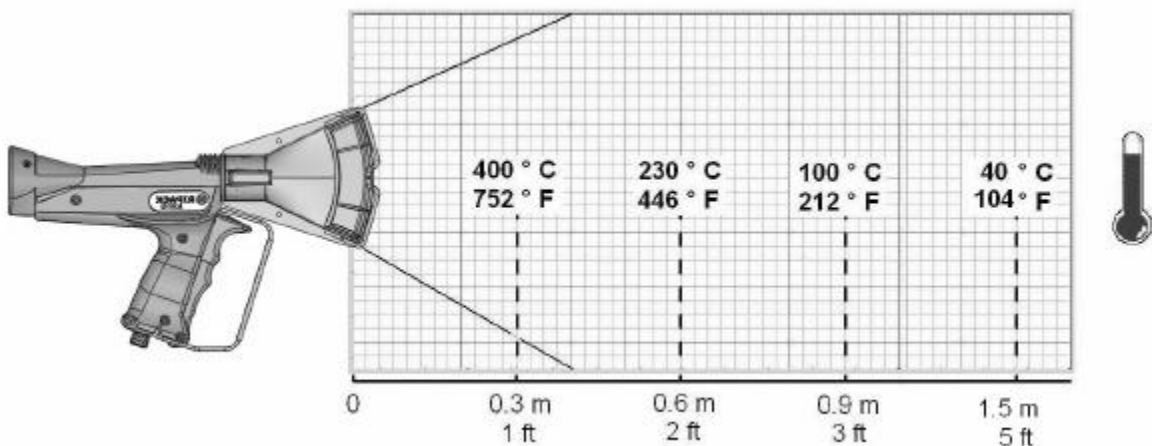

We draw the attention of operators to the fact that within the danger zone, there is a possible risk of burning for persons and animals, and goods can be damaged or catch fire.

This appliance, which is designed for applying plastic films by heating, can also be used for other purposes where the products can withstand the heat produced by a naked flame. Such use is explicitly the responsibility of the user. The manufacturer's guidelines of the product that is being handled must be followed at all times. In addition, the national, federal and local regulations with regard to the operation of appliances with a naked flame must also be respected.

To operate the appliance safely, you must follow the warnings mentioned above as well as the guidelines provided by the manufacturer of the materials being handled. The safety distance, the duration of exposure and the adjustment of the appliance for the different materials being handled, depend on the instructions provided by the manufacturer of the materials in question.

The RIPACK 2200 propane works with propane according to the principle of atmospheric air burners induced at high speed (diagram B).

Ignition is performed using a piezoelectric lighter that is activated simultaneously with the release of gas activated by the trigger, which is the sole operating mechanism.

The RIPACK 2200 is a gun incorporating several **safety mechanisms**.

Its original and patented design ensures combustion without heating of the combustion nozzle (**cold nozzle**).

A **security valve** system cuts off the gas supply in the event that the hose breaks or tears.

An automatic safety device (so-called dead man's switch) cuts the supply of gas automatically if the trigger is released. This **stops the heating immediately**. This dead man's device must never be blocked in the open position in any way.

A **guard in front of the trigger** prevents untimely operation.

Always contact your RIPACK distributor for all maintenance work and spare parts.

## PROPANE GAS APPLIANCE

### TECHNICAL CHARACTERISTICS:

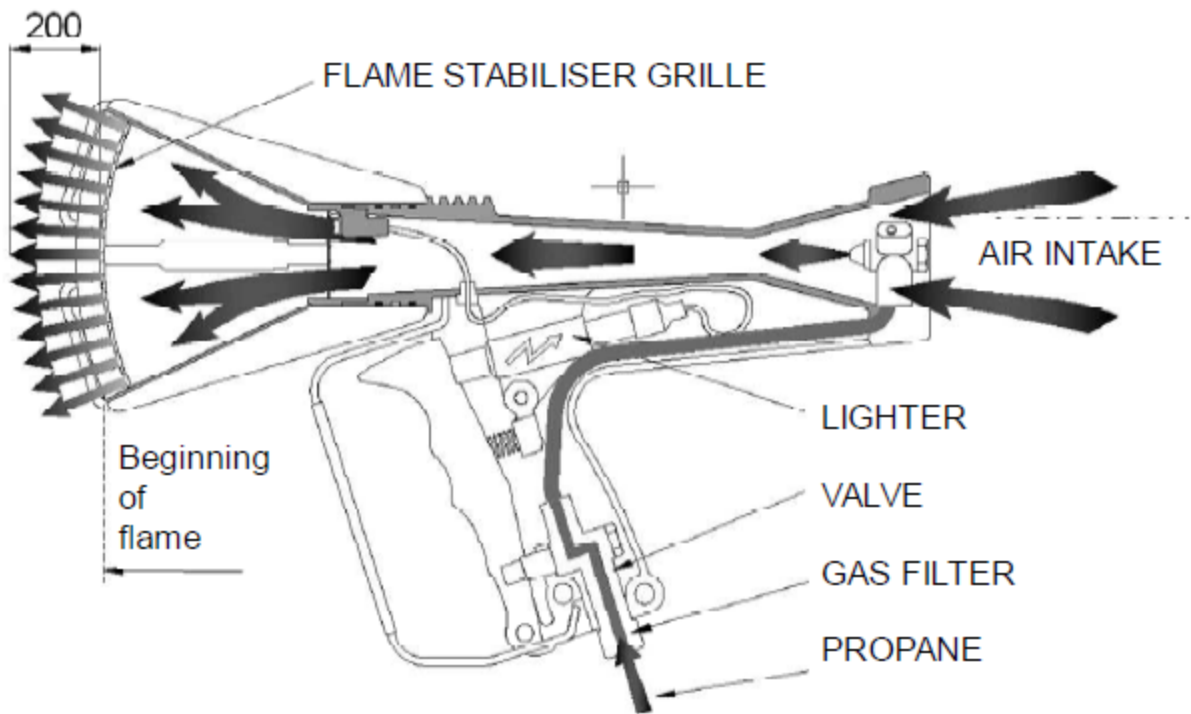

	SI system	Anglo-Saxon system
pressure	1.5 to 3.5 bar	21 to 50 psi
power	40 to 72 kW	136,000 to 245,000 btu/h
consumption	2.9 to 4.9 kg/h	6.4 to 10.8 lbs/h
air intake	35 to 63 m <sup>3</sup> /h	1,200 cu.ft/h to 2,200 cu.ft/h
CO emission	0.0046 to 0.0019 % vol	
CO <sub>2</sub> emission	2.5 to 3.6 % vol	
noise levels	<85 dbA	
length	36 cm 14 inches	
weight	1,160 g 2.55 lb	
energy source	propane	
other energy source	natural gas with conversion kit	

# OPERATION

BEFORE OPERATING THE APPLIANCE YOU MUST READ ALL THE WARNINGS MENTIONED ABOVE AND MAKE SURE THAT USING THE APPLIANCE IS NOT FORBIDDEN BY THE MANUFACTURER OF THE MATERIALS THAT YOU ARE GOING TO HANDLE .

WITH THIS APPLIANCE YOU MUST USE THE ORIGINAL HOSE AND SECURIPACK THAT WERE SUPPLIED.

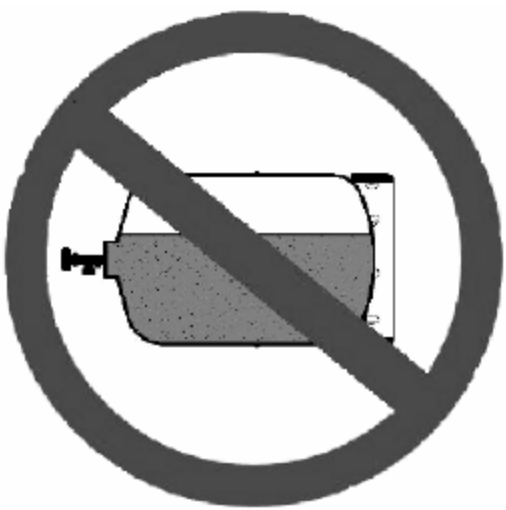
<b>FORBIDDEN FOR ALL USES</b>	
	
<b>LIQUID PROPANE GAS</b> (e.g. Fuel for forklift truck)	<b>BOTTLE ON ITS SIDE</b>

☺ The RIPACK 2200 works with **PROPANE** gas in **gas phase**, contained in bottles of different capacities.

Use the largest possible bottles available.

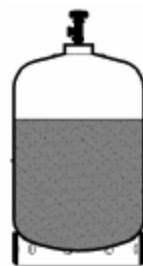

Always connect and disconnect the bottles a long way from any flames and ignition points.

For all work inside professional workshops, the bottle must be placed on a mobile trolley that can be manoeuvred easily.

# CONNECTIONS

Before connecting the SECURIPACK to the gas bottle, make sure the sealing gasket is positioned correctly for systems using this type of joint. In other cases, make sure the fitting is clean.

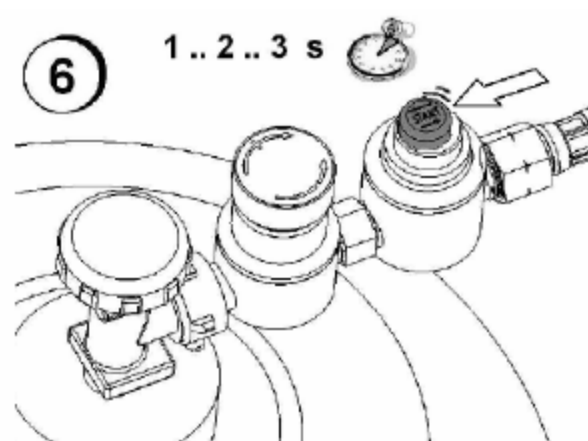
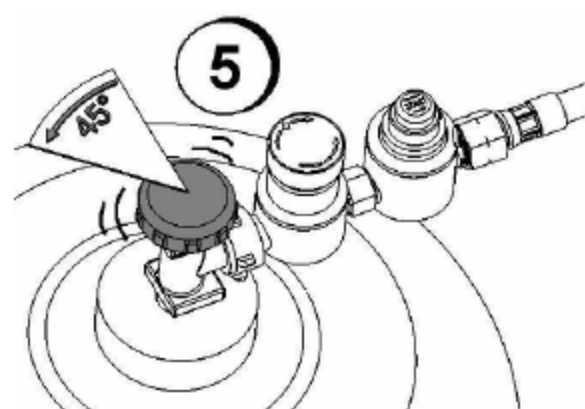
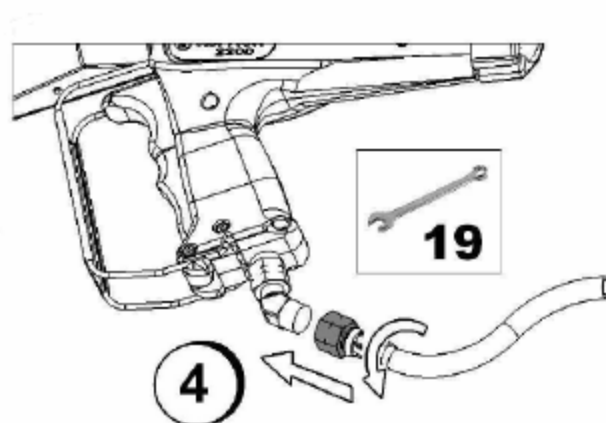
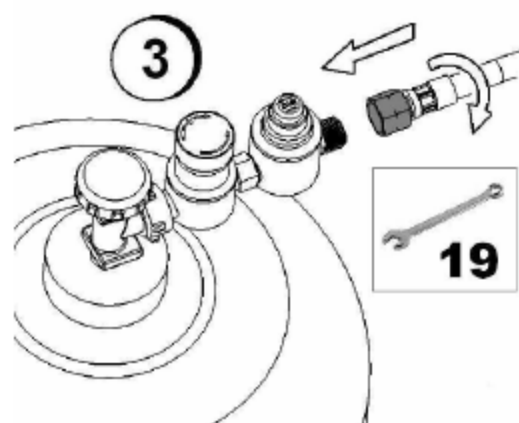
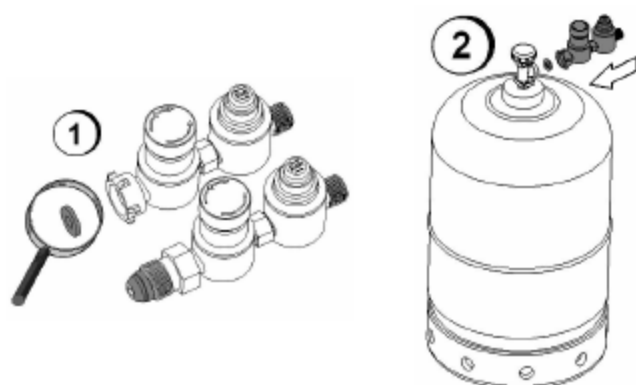

## TIGHTNESS:

Use a bubble spray or some soapy water to check that there are no leaks in the **parts** that have been **screwed together** (bottle, hose and gun connections).

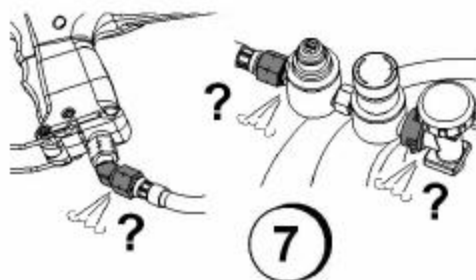

## IGNITING THE RIPACK 2200

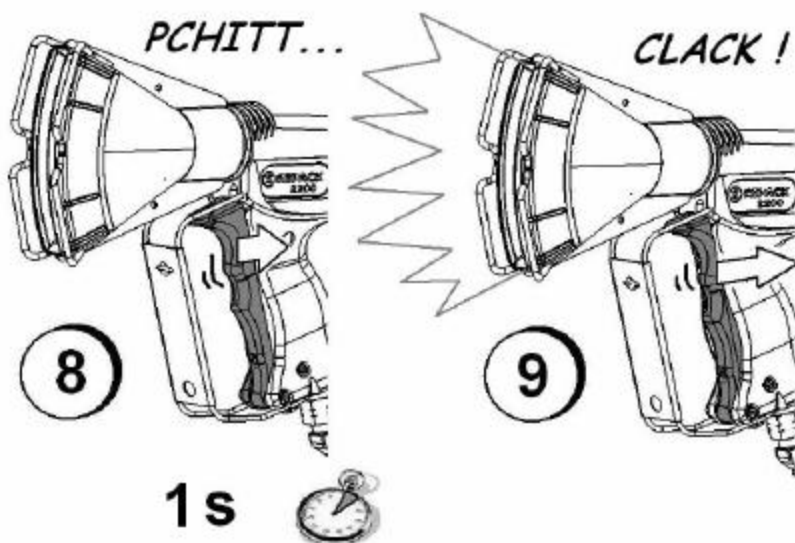

## POWER KNOB

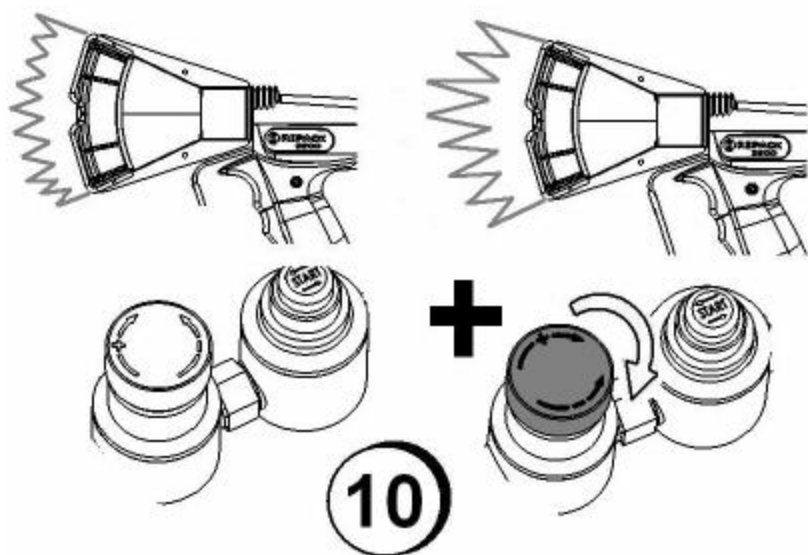

The SECURIPACK automatically cuts off the supply of gas if the pressure drops below the minimum level necessary for the normal efficiency of the work.

This is the case when:

- The bottle is nearly empty (the gun can only be used for a few more minutes at reduced power: change the bottle);
- The temperature of the bottle has dropped after intensive use (icing): if this is the case, change the bottle temporarily or wait until the normal pressure returns, especially if you are working outside (0°C / 30°F and colder).

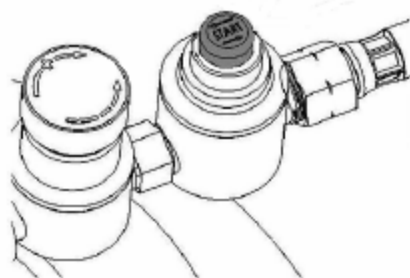

**NEVER HEAT A GAS BOTTLE WITH A FLAME.  
WHEN YOU HAVE FINISHED WORKING,  
ALWAYS CLOSE THE GAS BOTTLE VALVE  
AND EMPTY THE HOSE BY PRESSING THE  
TRIGGER.**



## SPARE PARTS

**THE COMPANY RIPACK SHALL NOT BE HELD LIABLE IN THE EVENT THAT THE GUN IS DISMANTLED.**

**Contact your dealer if the RIPACK 2200 needs to be dismantled.**

Only the procedures described in the maintenance chapter are authorised.

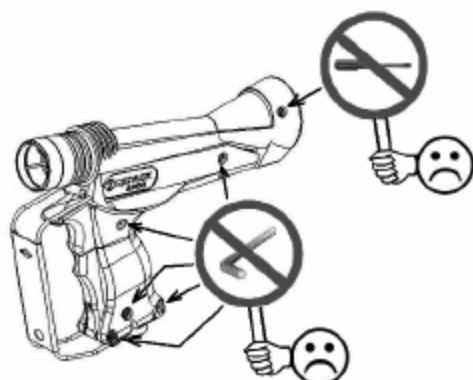

# EXEMPLE OF USE

## *Shrink-wrapping a loaded pallet*

Ask your film supplier for the operating instructions.

The pallet must be lifted so that the four corners are accessible: the purpose of this is to allow the film to be shrunk under the pallet and so ensure very strong cohesion between the pallet and the load it supports. You will find an accessory in the RIPACK product range that is designed specially to keep pallets lifted from the ground: the CALPACK (contact your dealer).

Slide the shrink cover, which must be about 5% wider than your pallet and sufficiently long to be able to be shrunk under the pallet (H plus 200 mm).

Ignite your RIPACK 2200 as explained in the chapter "Operation".

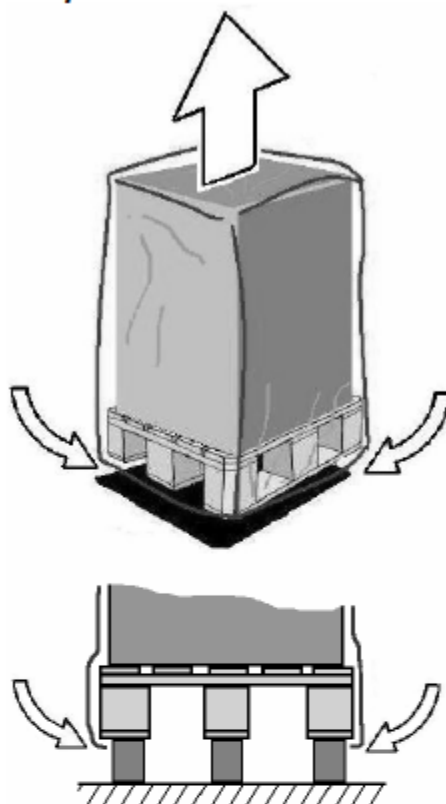

## SHRINK-WRAPPING RECOMMENDATIONS

(in the absence of instructions provided by the film manufacturer):

Remain at a distance of at least about 30 centimetres from the film and start shrink-wrapping the lower part of the four sides so the pallet is shrink-wrapped underneath. Make sure you point the air flow perpendicularly along the sides of the pallet.

Apply the heat in a continuous movement and at a constant speed.

**NEVER STAY ON THE SAME SPOT.**

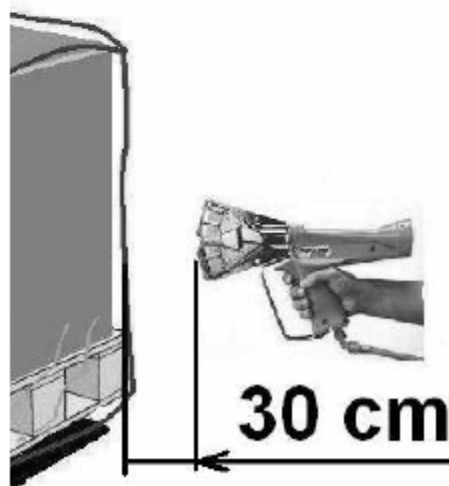

The various films react differently, so you must observe the reaction and adapt your speed and movement and/or the distance between the nozzle and the film accordingly.

You can also adjust the power of the RIPACK 2200 with the adjustable SECURIPACK controls.

Once the lower part of the pallet has been shrink-wrapped, continue the operation for each side and move from top to bottom to cover the entire height.

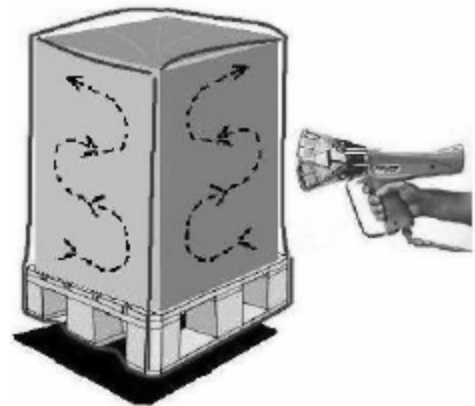

Once the 4 sides have been shrink-wrapped, you can do the top by applying the hot air to the top of the pallet.

Caution: The film is already stretched along the sides so you should apply less heat on the top in order to prevent the cover from being damaged.

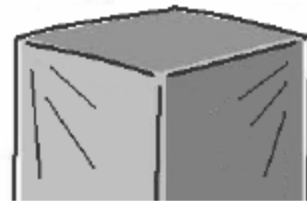

When you have stopped applying heat with the gun, the plastic film, because of its make-up, will continue to shrink for some time. This time will vary depending on the quality, the thickness and the type of load that has been wrapped. It is recommended therefore that you wait until the cover has cooled off and everything is tight before moving the pallet.

After cooling and before storage, always check that the cover and the wrapped goods are in good condition.

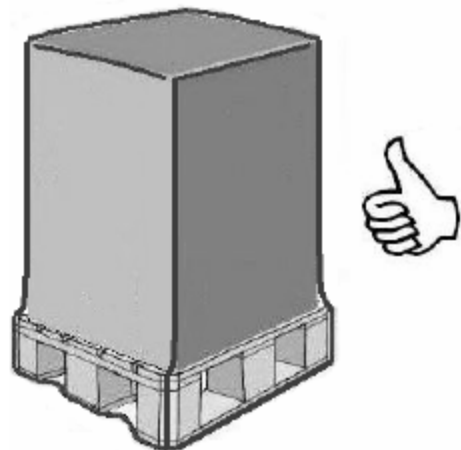

**CHECK CAREFULLY FOR AT LEAST 2 HOURS  
AFTER SHRINK-WRAPPING**

## Packaging

All kinds of objects with irregular shapes can also be packaged using shrink-wrap film.

To obtain a good film joint, you need to provide a minimum overlap of 30 cm (diagram M).

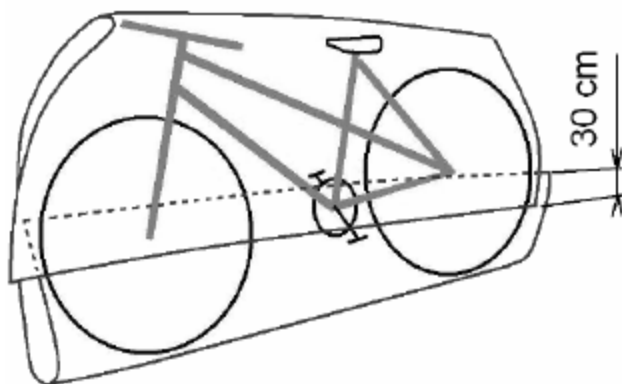

Start by heating the film in a continuous movement and then put pressure on this part using a spatula to connect the two parts together.

Once the joint has been made, continue the shrink-wrapping by holding the appliance at least 30 cm from the film. When doing this, be sure to follow the recommendations for shrink-wrapping.

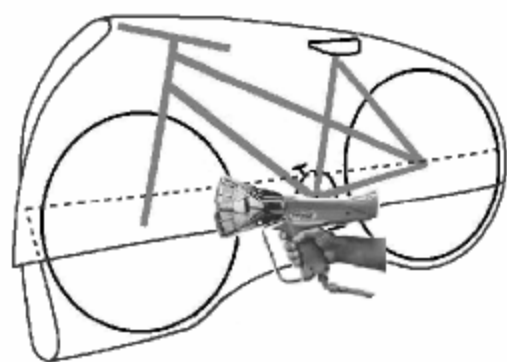

**NOTE:** The combustion nozzle can rotate freely and this will make your work easier (diagram P).

Put the nozzle in the required position.

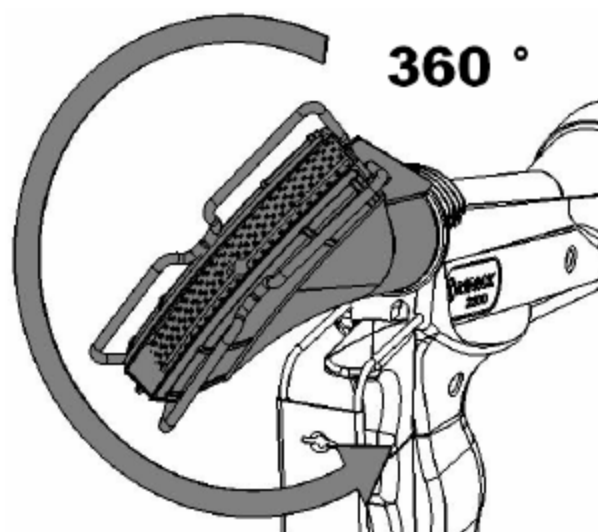

## **Verification of the SECURIPACK:**

The correct functioning of the safety mechanism must be checked for hose rupture (incorporated in the SECURIPACK) at least every 500 hours or every three months. This is to be performed as follows:

- Go outside, a long way from any flame source, sparks and any objects that ignite.
- Apply pressure to the appliance. With the spanner supplied, loosen the connecting nut of the hose and unscrew completely: the gas supply will now be cut off automatically.

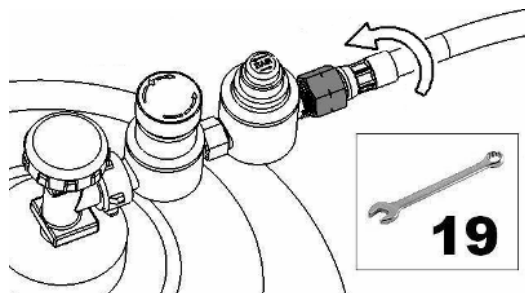

## **Verification of the RIPACK 2200:**

DAYLY before starting to work:

1. Check the condition of the hose along its whole length and at the fittings.

We recommend that you replace the hose in the following cases:

- When a visual inspection has revealed damage (cuts), even if the damage is superficial.
- Every 3 years if used intensively.
- At the latest 5 years after first use.

Note: The date on the hose is the manufacture date.

**Only use a replacement hose supplied by RIPACK with its original fittings!**

2. Check as follows that the dead man's safety mechanism works correctly:

When you are not working, follow the procedure described in steps 8 and 9 of the chapter "Operation/igniting the RIPACK 2200" and release the trigger immediately. The nozzle will go out immediately.

If any of the parts you checked show flaws, please contact your RIPACK dealer.

## Cleaning:

Frequency:

Non-polluted environment: Every 500 hours.

Polluted environment: As soon as it is noticed that there is a reduction in power.

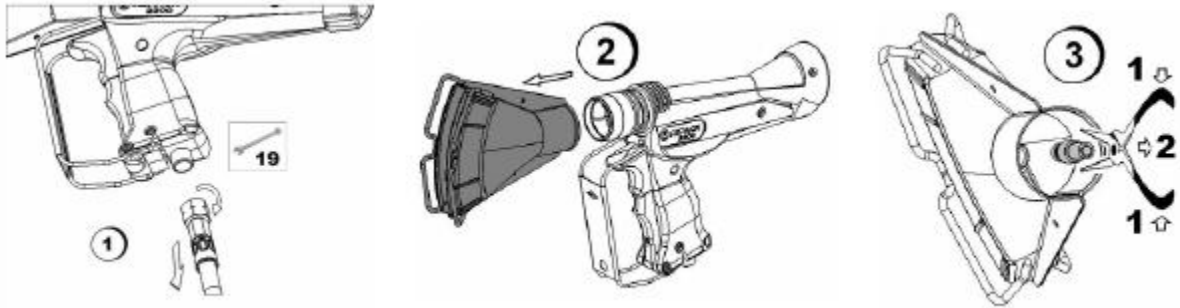

### CLEANING THE NOZZLE GRILLE:

- Place the nozzle for a few minutes in a dry petrol bath (e.g. F petrol) to make sure the various tightness systems are not damaged. Grease products (e.g. oil) are not recommended because they attract impurities afterwards.

### **NEVER USE ANY OTHER DEGREASING PRODUCTS FOR CLEANING.**

- Clean the inside and the outside of the nozzle grille with a paintbrush or a hard brush.
- Clean the receiving tube of the spark plug.
- Rinse it again and apply compressed air (block the hole on the grille side intermittently For intensive blowing of the inside of the receiving tube).
- Put the spark plug back into position and check that it is pressed far enough.

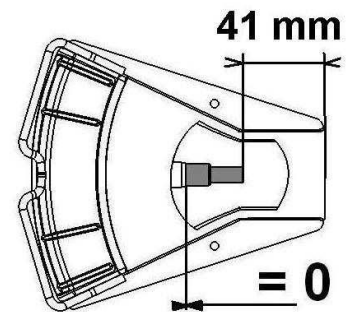

**OK**

Incorrect positioning may cause the electric contact of the spark plug to deteriorate.

### CLEANING THE VENTURI:

The venturi must be cleaned in dry condition.

- Clean the venturi with a paintbrush or a hard brush.
- Apply compressed air in the direction of the injector/nozzle to avoid polluting the injector.

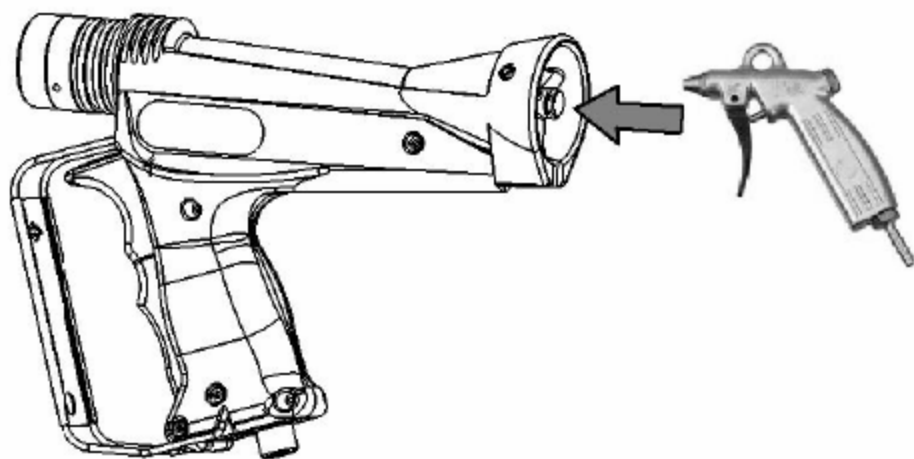

- Test the operation by performing the procedures in the chapter "Operation". If the gun has not regained its full power, clean the injector.

### CLEANING THE INJECTOR:

**WARNING:** Do not dismantle the injector support (2 screws with slotted head).

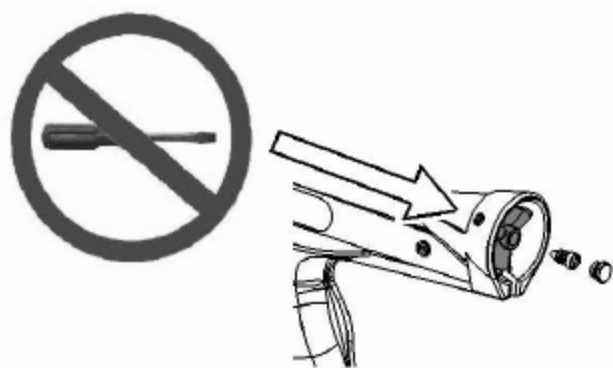

**Note:** The injector support is aligned in the factory with special tools in order to obtain maximum efficiency of the flame.

Dismantle the throttle with a number 12 spanner.

- With a special screwdriver, remove the injector, put it down, rinse it with petrol and blow out.
- Reassemble the injector after you have dried the sealing gasket on top.
- Fasten the injector without forcing it.
- Carefully reassemble the throttle by screwing it all the way on and make sure the hexagon is flat on the injector support.
- Test the operation by performing the procedures in the chapter "Operation".

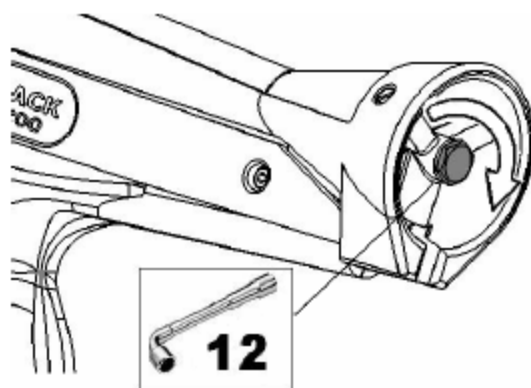
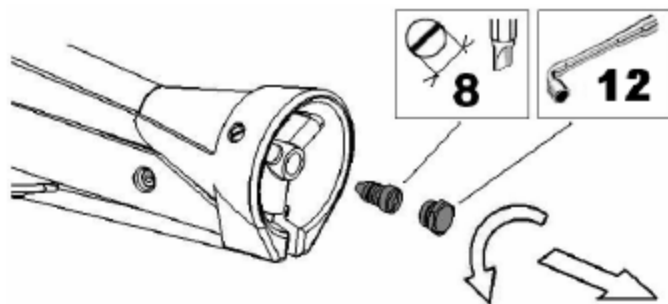

**FOR ALL OTHER INTERVENTIONS RELATED TO THE GAS CIRCUIT,  
PLEASE CONTACT YOUR RIPACK DEALER.**





#### MAINTENANCE OF THE FITTINGS:



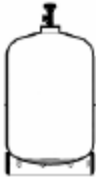

Lubricate the fittings with "MOLYKOTE 1102 GAS COCK GREASE" or equivalent.

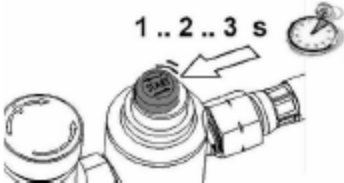
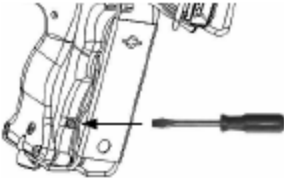

Note: Sealing product NBR.

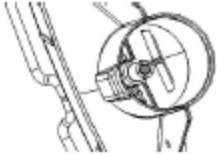

## Obtaining the best results with your RIPACK 2200:

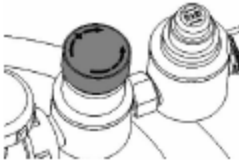
PROBLEMS	CAUSE	REMEDIES
The combustion nozzle doesn't/is difficult to ignite.	Empty bottle. 	Check that there is gas in the bottle (if necessary, change the bottle).
	Bottle valve is closed. 	
	Pressure-reducing valve not set up. 	
	The gun valve filter is blocked.	Have your appliance checked by your RIPACK dealer.
	The gun valve doesn't open properly.	With the appliance under pressure, screw the screw so it touches the piston of the valve without pressing the trigger; this compensates any slack that may be present as a result of using the appliance. 
	Injector is blocked.	Unblock the injector. (See "Cleaning".)

PROBLEMS	CAUSE	REMEDIES
The combustion nozzle doesn't/is difficult to ignite.	Bad contact or bad insulation.	<p>Check the contact at the spark plug end.</p>  <p>Check the contact in the sleeve.</p> 
	Piezoelectric lighter run down.	Contact your RIPACK dealer.
	Electrode burnt or broken.	<p>Change the spark plug (see "Cleaning").</p> 
	Combustion nozzle is dirty.	<p>Clean the nozzle grille (see "Cleaning").</p> 
The combustion nozzle has insufficient power.	The gas bottle valve is open too far.	
	The pressure control of the SECURIPACK is not in its maximum position.	
	The gas you are using is not propane.	Use propane gas.
	The bottle capacity is too low.	Use a bottle with a larger capacity.

PROBLEMS	CAUSE	REMEDIES
<p>The combustion nozzle has insufficient power.</p>	<p>The ambient temperature is low and the appliance is being used intensively.</p> 	<p>Alternate between several bottles.</p>
	<p>The injector is blocked.</p>	<p>Clean the injector (see "Cleaning".)</p>
	<p>The rubber hose is twisted.</p>	<p>Put it back in its initial position.</p>
<ul style="list-style-type: none"> <li>• Flame is lower.</li> <li>• Internal combustion.</li> <li>• Combustion nozzle gets hot.</li> </ul>	<p>The nozzle grille is blocked by particles suspended in the air (working in polluted environment).</p>	<p>Clean the grille and the venturi of the RIPACK 2200 (see "Cleaning").</p> 
<p>The combustion nozzle does not go out immediately.</p>	<p>The trigger valve is jammed or blocked.</p> 	<p>Close the gas bottle valve and have your appliance checked by your RIPACK dealer.</p>

# WARRANTY

Your RIPACK 2200 appliance has been manufactured with the greatest care using quality materials. Numerous tests and inspections were carried out during production.

Every component meets the requirements of strict specifications in order to guarantee performance and adaptability.

For all maintenance work and spare parts, your RIPACK dealer ensures the supply of spare parts in accordance with the RIPACK requirements, guarantee of quality and of safety.

## RIPACK WARRANTY:

WARRANTY OF OPERATION for one year under the following conditions:

- that the appliance has been used in compliance with the user's guide;
- that the appliance has not been disassembled except for the procedures described in the user's guide;
- that the appliance is physically intact (for example: the body of the appliance, the protective guard and the combustion nozzle grille must not be deformed in any way, and, for example, the thread of the fittings must be intact).

This warranty does not apply to the following replacement parts:

- lighter
- hose.

All replacement parts must be original RIPACK spare parts. The manufacturer shall not be held responsible and shall not be liable for any claims in the event that the aforementioned warnings and instructions are not respected.

The company RIPACK shall not be held responsible for accidents involving persons or goods which arise from the incorrect use of the appliance or from using it for an application which is not specifically mentioned in the user's guide.

All disputes shall be governed by the courts of Bordeaux - France. No other place of jurisdiction shall be accepted.

The use and the resale of the RIPACK 2200 implies the acceptance of the aforementioned terms and conditions.

IN THE EVENT OF A WARRANTY CLAIM, PLEASE ATTACH A COPY OF YOUR SUPPLIER'S INVOICE.

# RIPACK® 2200

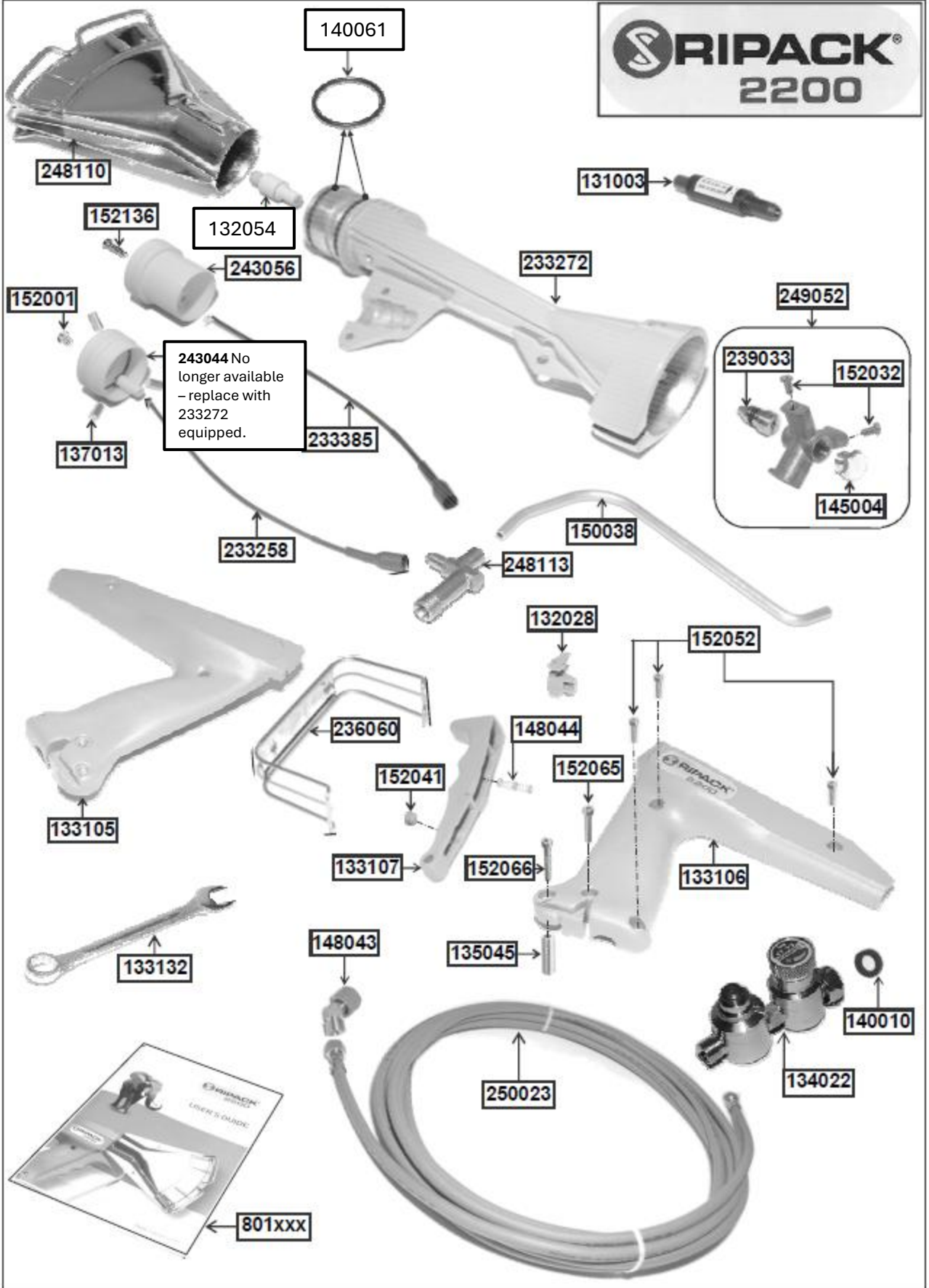

**FOR EXTENSIONS ON RIPACK 2200**

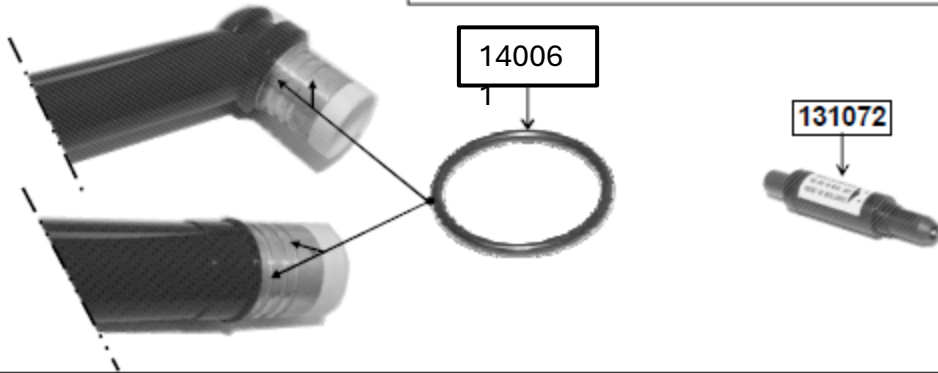

**NATURAL GAS CONVERSION KITS ON RIPACK 2200**

For pressures from 0.5 to 1.4 bar / 7.3-20 psi

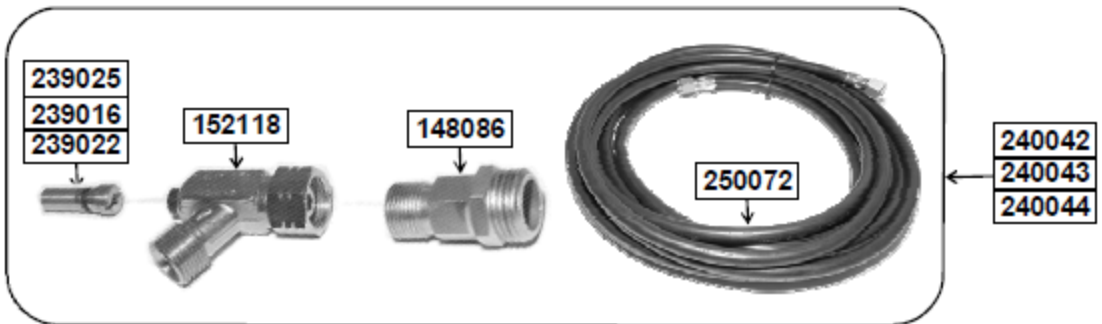

For pressures from 1.5 to 3 bar / 22-44 psi

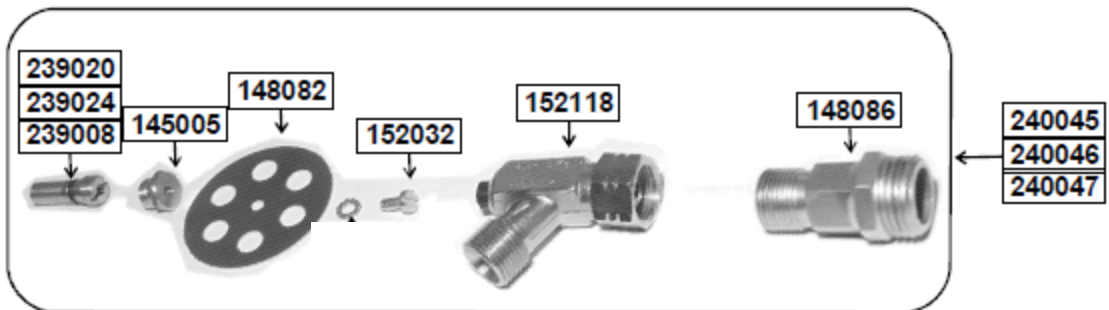

Code article	Désignation
131003	Piezo igniter for RIPACK 2200 without extension
131072	Piezo igniter for RIPACK 2200 <b>with</b> extension
132028	Handle front block
133105	Half-handle, right
133106	Half-handle, left
133107	Trigger
133132	Wrench 19
134022	SECURIPACK- including adjustable pressure regulator and double safety, NF standard
135045	Trigger spacer
137013	Flute pin 3x6 for RIPACK 2200 <b>before</b> serial No. 09.197868 (week 04/09)
140010	Flat seal on SECURIPACK NF - UNI
140061	O-ring - inside Ø 28.24 x Ø 2.62 DIN
143005	Double connector 3/8 G
145004	Jet cover nut
145005	Jet cover nut special for natural gas
148001	Fan washer Ø 4
148043	Swivel connector
148044	Trigger return spring
148082	Stainless steel washer Ø 47.5 for air reducer for natural gas conversion kit
148086	Male mains connector 3/8 G 15/21 (1/2) for natural gas conversion kit
150038	Gas brass tube
152001	Stainless steel slotted screw TC M3x4 on RIPACK 2200 <b>before</b> serial No. 09.197868 (week 04/09)
152032	Slotted screw TC M4x8
152041	Nylon setscrew M8x6 - Tap adjustment
152052	Screw CHc M4x16
152065	Screw CHc M4x25
152066	Screw CHc M4x30
152118	Safety valve 3/8 5 kg/h for natural gas conversion kit
152136	Slotted screw TC M3x12 for 2200 <b>after</b> serial No. 09.197869 (week 05/09)
132054	Spark plug

Code article	Désignation
233258	Ignition wire fitted with rubber cap and grommet nut for RIPACK 2200 <b>before</b> serial No. 09.197868 (week 04/09)
233272	Shrink gun body with O-rings, sleeve + ignition wire / 2200
233385	Ignition wire fitted with rubber cap and grommet nut for RIPACK 2200 <b>after</b> serial No. 09.197869 (semaine 05/09)
236060	Guard support wire + guard plate assembled set
239008	Special jet - natural gas pressure 1.5 to 2 bar (22 to 29 psi)
239016	Special jet - natural gas pressure 0.8 to 1 bar (12 to 15 psi)
239020	Special jet - natural gas pressure 2.6 to 3 bar (38 to 44 psi)
239022	Special jet - natural gas pressure 0.5 to 0.8 bar (7.3 to 12 psi)
239024	Special jet - natural gas pressure 2.1 to 2.5 bar (30 to 36 psi)
239025	Special jet - natural gas pressure 1.1 to 1.4 bar (16 to 20 psi)
239033	Standard jet - propane - DIN
240042	Natural Gas Conversion Kit for pressure 0.5-0.8 bar (7.3-12 psi)
240043	Natural Gas Conversion Kit for pressure 0.8-1 bar (12-15 psi)
240044	Natural Gas Conversion Kit for pressure 1.1-1.4 bar (16-20 psi)
240045	Natural Gas Conversion Kit for pressure 1.5-2 bar (22-29 psi)
240046	Natural Gas Conversion Kit for pressure 2.1-2.5 bar (30-36 psi)
240047	Natural Gas Conversion Kit for pressure 2.6-3 bar (38-44 psi)
240049	Air reducer kit for Natural Gas Conversion Kits for pressure 1.5-3 bar (22-44 psi)
243044	Neck casing equipped with plastic ring and spring ring for RIPACK 2200 <b>before</b> serial No. 09.197868 (week 04/09) <b>No longer available</b>
243056	Neck casing equipped with plastic ring and spring ring for RIPACK 2200 <b>after</b> serial No. 09.197869 (week 05/09)
248110	Combustion nozzle
248113	Gas tap, DIN
249052	Jet bearer complete, DIN (includes: bearer, jet, screw, jet cover nut)
250023	High pressure hose, DIN, Length 8 meters, inside Ø: 4, with clamps and fittings
250072	High pressure hose, UL, Length 7.5 meters, inside Ø: 6, with clamps and fittings
801xxx	User's manual



**DECLARATION DE CONFORMITE CE  
EC- DECLARATION OF CONFORMITY**



Avenue de Magudas  
3 Rue de Betnoms  
33187 LE HAILLAN Cedex  
France

Déclare que le produit :  
*Hereby declares that:*

**RIPACK 2200**

Destiné à la production d'une flamme produite par la combustion de gpl  
*Designed to produce a flame produced by the combustion of LPG*

A partir du numéro de série : 06 133 360  
*From Serial Number : 06 133 360*

est certifié GS par le laboratoire DVGW sous le N° DG-2418BR0325  
*is GS certificated from the DVGW laboratory under number DG-2418BR0325*

Fait au Haillan, le 01 mars 2006  
*Le Haillan, March 01st, 2006*

Le Président  
*President*