



GROUPE SEFMAT

RIPACK®

USER'S GUIDE

RIPACK 2500



YOUR PROTECTION
BY EXCELLENCE

REGISTER YOUR PRODUCT
ONLINE WARRANTY CONTRACT
[WWW.RIPACK.COM/ EN/REGISTER-A-PRODUCT/](http://WWW.RIPACK.COM/EN/REGISTER-A-PRODUCT/)



TOOL BAG CONTENT



Securipack
Pressure
Regulator

Wrench

Swivel
connector

8 m gas
hose

User's
guide



GROUPE SEFMAT

RIPACK®

Ripack 2500

**HAND-HELD PROPANE-FIRED SHRINK GUN FOR
SHRINK-WRAPPING PLASTIC FILMS**

USER'S GUIDE











CONTENTS

WARNINGS	5
OPERATION	10
CONNECTIONS	11
EXAMPLES OF USE	13
MAINTENANCE	14
SPARE PARTS	16
WARRANTY	21
EXPLODED VIEW	22
SPARE PARTS LIST	24
DECLARATION OF CONFORMITY	25

WARNINGS

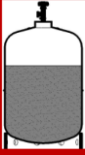

TO BE READ BEFORE STARTING FOR THE FIRST TIME.

	Do not use this device in regulated areas with specific fire or explosion hazards.
	Do not use the device to shrink the plastic film on a floor made of combustible material (wood, plastic, etc...).
	Delineate a working area such that the tip of the thermal lance is always at least more than 1,5 m inside this area and prohibit access to unauthorized individuals.
	Make sure there are no leaks on the fittings and inspect the pipe for cracks or loose connections.
	Must hand an appropriate fire extinguisher or suitably-sized spray filled with water.
	Avoid wearing highly flammable nylon or similar clothing.
	Wear heat-resistant gloves while using the device.
	Maintain strict supervision for at least 2 hours after retraction.
 PROPANE	Check that the regulator fits properly with the gas cylinder.

This appliance is meant exclusively for professional use and for shrinking plastic films.

Users of the Ripack 2500 shrink gun must read this user's guide completely and must be trained for the applications that require the use of this appliance.

This user's guide must be kept for future reference.

Do not use this appliance for shrinking plastic film on materials, substances, products or liquids that inflame spontaneously, either processed in bulk or packed, and do not use the appliance in the storage areas of these products or in spaces where it is explicitly forbidden to smoke for safety reasons.

Do not use this appliance for shrinking plastic film on a floor that is made of combustible material (wood, plastic, etc..).

Close the valve of the gas bottle when not in use for long periods of time.

Press the trigger to empty the gas hose and release the pressure.

Never heat a specific area continuously.

Keep the working zone clean and remove all waste (wood, paper, other inflammable materials).

For all work inside professional workshops, the gas bottle must be placed on a mobile trolley that can be maneuvered easily.

This appliance, like all other gas appliances, consumes air and produces combustion fumes that contain CO₂ and CO. Exposure to high concentrations of the latter gas is lethal. Make sure there is sufficient ventilation in accordance with the amount of time the appliance is used (see «Technical Characteristics»).

We recommend that the appliance be used in a room without specific pollution which has a minimum volume of 16 m³ (fresh air flow: 48m³/h).

Never work in a basement.

Before using the appliance, make sure that you are conforming to the guidelines for using liquid gas.



In operation, this appliance produces a flame. Do not point the flame towards yourself, other persons or animals, towards the gas bottle or the hose, or towards inflammable materials.



Please refer to the **regulations applicable in the country of use** concerning the conformity and use of the products and accessories offered in our Ripack ® range. The use of Ripack ® accessories, connections and spare parts is essential for the correct operation and guarantee of our products and for the safety of people and property.

In operation, the appliance creates a danger zone up to 0,9 meters (3 feet) in front of the fire nozzle.

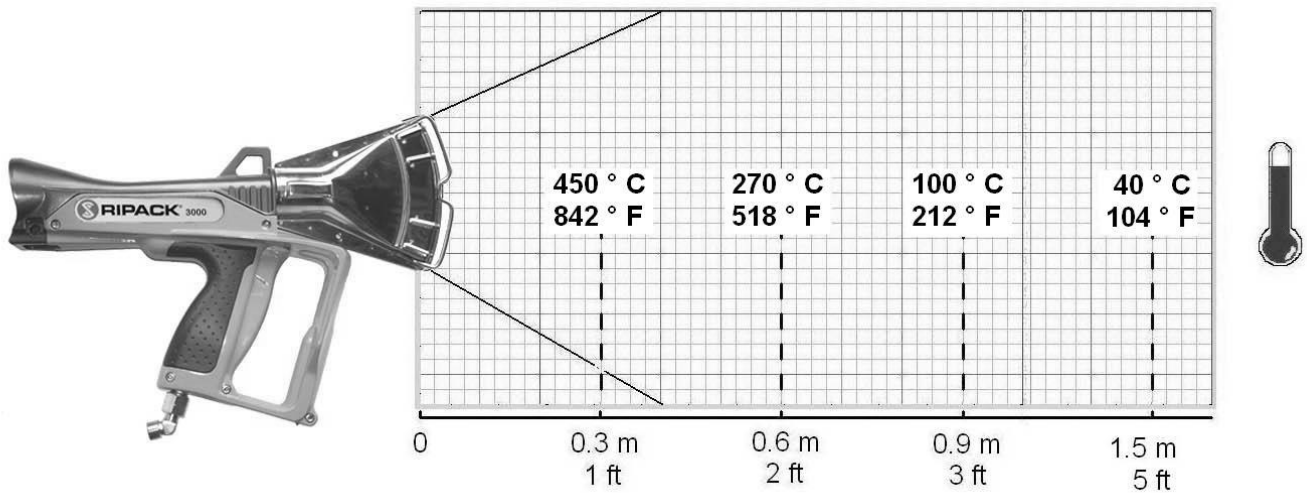

We draw the attention of operators to the fact that within the danger zone, there is a possible risk of burning for persons and animals, and goods can be damaged or catch fire.

In use, the gun must always be in motion so that the material used does not exceed the maximum temperature specified by the supplier.

This temperature depends on the operating distance, the exposure time and the power setting of the camera.

This appliance, which is designed for applying plastic films by heating, can also be used for other purposes where the products can withstand the heat produced by a naked flame. Such use is explicitly the responsibility of the user. The manufacturer's guidelines of the product that is being handled must be always followed. In addition, the national, federal and local regulations about the operation of appliances with a naked flame must also be respected.

To operate the appliance safely, you must follow the warnings mentioned above as well as the guidelines provided by the manufacturer of the materials being handled. The safety distance, the duration of exposure and the adjustment of the appliance for the different materials being handled, depend on the instructions provided by the manufacturer of the materials in question.

Always contact your RIPACK distributor for all maintenance work and spare parts.

The RIPACK 2500 propane works with propane according to the principle of atmospheric air burners induced at high speed (diagram B).

Ignition is performed using a piezoelectric lighter that is activated simultaneously with the release of gas activated by the trigger, which is the sole operating mechanism.

The RIPACK 2500 is a gun incorporating several safety mechanisms:

- Its original and patented design ensures combustion without heating its combustion nozzle (cold nozzle).
- A security valve system cuts off the gas supply if the hose breaks or tears.
- An automatic safety device (so-called dead man's switch) cuts the supply of gas automatically if the trigger is released. This stops the heating immediately. This dead man's device must never be blocked in the open position in any way.
- A guard in front of the trigger prevents untimely operation.

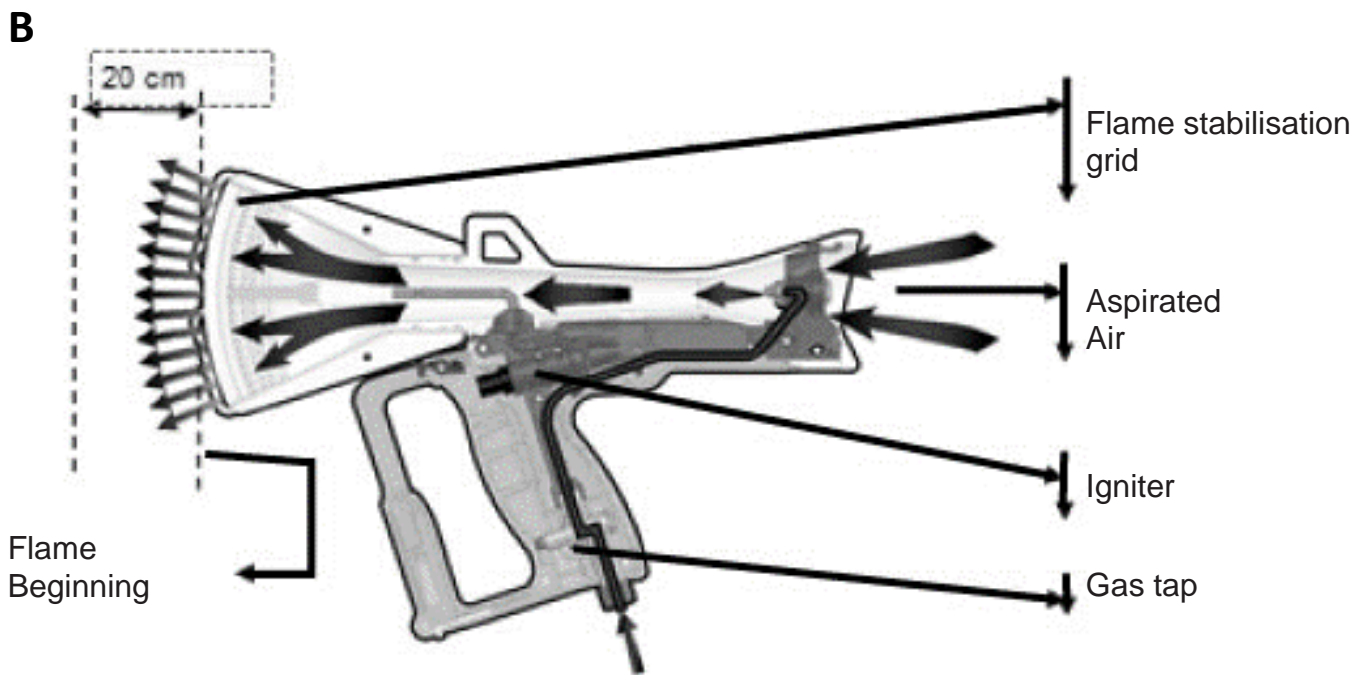

PROPANE GAS APPLIANCE

TECHNICAL CHARACTERISTICS :

	SI SYSTEM
Pressure (bar)	1,5 to 3,5
Power (kW)	34 to 60
Consumption (kg/h)	2,2 to 4
Air intake (m ³ /h)	30 to 54
CO emission vol %	0,004 to 0,002
CO ₂ emission vol %	2,81 to 4
Noise level	< 85 dbA
Length	36 cm
Weight	940 g
Energy source	Propane gas
	ANGLO-SAXON SYSTEM
Pressure (PSI)	21 to 50
Power (btu/h)	116 013 to 204 728
Consumption (lbs/h)	5 to 9
Air intake	1030 cu.ft/h to 1846 cu.ft.h
CO emission vol %	0,004 to 0,002
CO ₂ emission vol %	2,81 to 4
Noise level	< 85 dbA
Length	14 inches
Weight	2,11 lb
Energy source	Propane gas

OPERATION

BEFORE OPERATING THE APPLIANCE, YOU MUST READ ALL THE WARNINGS MENTIONED ABOVE AND MAKE SURE THAT USING THE APPLIANCE IS NOT FORBIDDEN BY THE MANUFACTURER OF THE MATERIALS THAT YOU ARE GOING TO HANDLE.

WITH THIS APPLIANCE YOU MUST USE THE ORIGINAL HOSE AND SECURIPACK THAT WERE SUPPLIED.

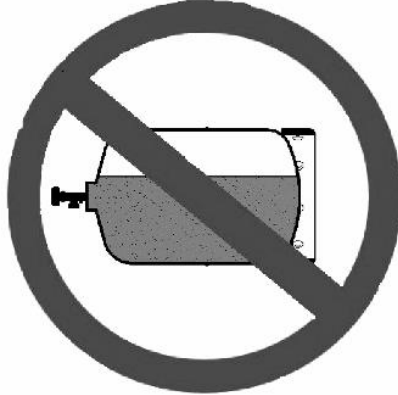
FORBIDDEN WITH ALL USES	
	
LIQUID PROPANE GAS (e.g Fuel forklift truck)	BOTTLE ON ITS SIDE

The Ripack 2500 works with PROPANE gas in gas phase, contained in bottles of different capacities.

Use the largest possible bottles available.

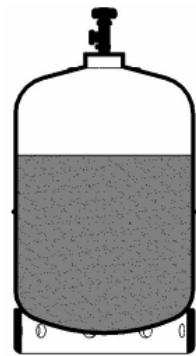

Always connect and disconnect the bottles a long way from any flames and ignition points.

For all work inside professional workshops, the bottle must be placed on a mobile trolley that can be maneuvered easily.

Before the first connection, the hoses must be cleaned by blowing. Air or nitrogen should be used for blowing. If nitrogen is used, it must be vented safely to the outside.

CONNECTIONS

Before connecting the SECURIPACK to the gas bottle, make sure the sealing gasket is positioned correctly for systems using this type of joint. In other cases, make sure the fitting is clean.

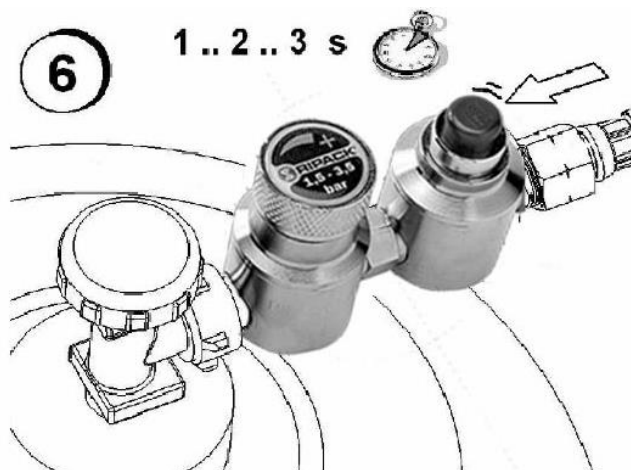
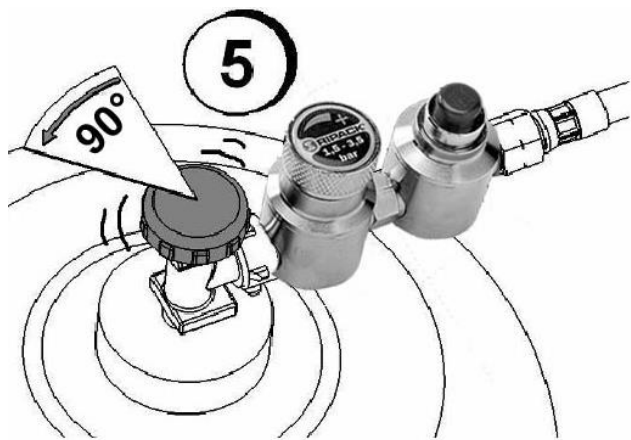
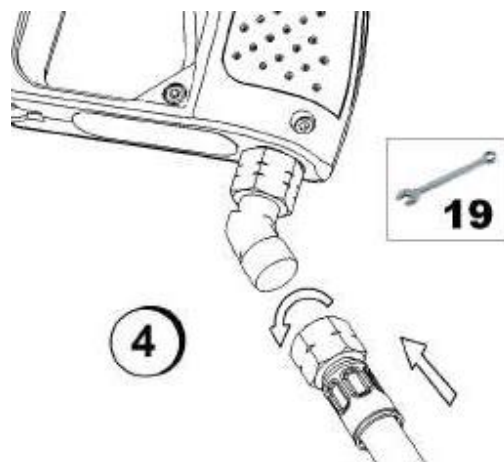
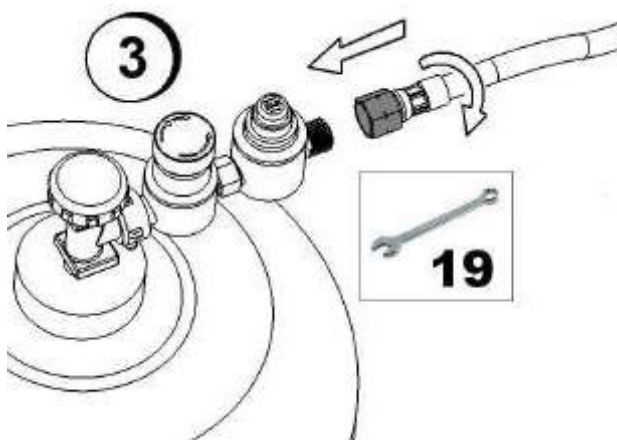
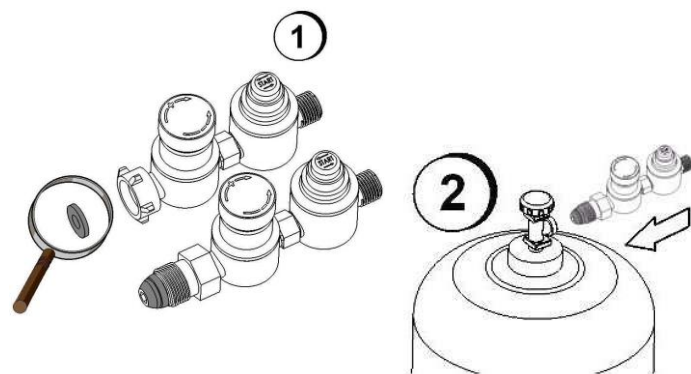

It is MANDATORY to use our regulators and original parts for optimal performance of our shrink guns.

The regulator is located in the front pocket of the carrying bag.

TIGHTNESS

Use a bubble spray or some soapy water to check that there are no leaks in the parts that have been screwed together (bottle, hose and gun connections).

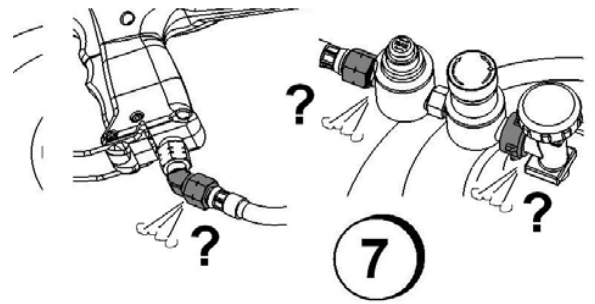

IGNITING THE RIPACK 2500



POWER KNOB

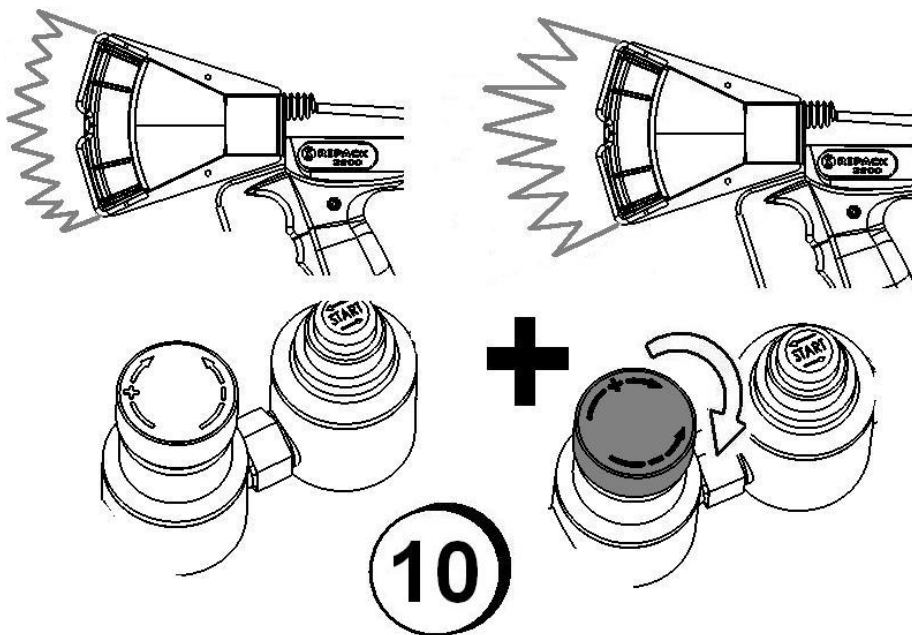

NEVER WORK WHILE HOLDING THE RED BUTTON.

The SECURIPACK automatically cuts off the supply of gas if the pressure drops below the minimum level necessary for the normal efficiency of the work.

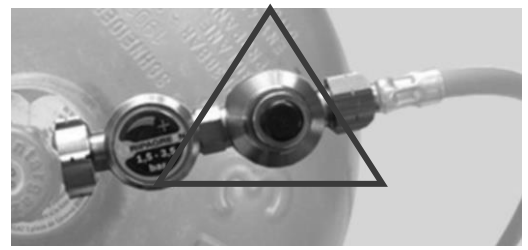

This is the case when:

- The bottle is nearly empty (the gun can only be used for a few more minutes at reduced power: change the bottle);
- The temperature of the bottle has dropped after intensive use (icing): if this is the case, change the bottle temporarily or wait until the normal pressure returns, especially if you are working outside (0°C / 30°F and colder).

NEVER HEAT A GAS BOTTLE WITH A FLAME.

WHEN YOU HAVE FINISHED WORKING, ALWAYS CLOSE THE GAS BOTTLE VALVE AND EMPTY THE HOSE BY PRESSING THE TRIGGER.



Once you have finished using your shrink gun, be sure to drain the remaining gas from the extension. To do this, turn off the gas supply and the regulator and pull the trigger slightly to purge the gas in the tube.

SPARE PARTS

THE COMPANY RIPACK SHALL NOT BE HELD LIABLE IN THE EVENT THAT THE GUN IS DISMANTLED.

Contact your dealer if the RIPACK 2500 needs to be dismantled.
Only the procedures described in the maintenance chapter are authorized.

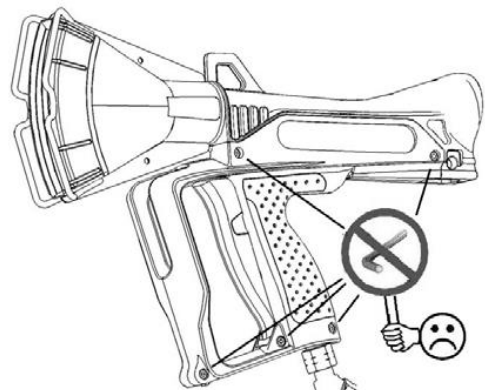

EXAMPLES OF USE

SHRINK-WRAPPING A LOADED PALLET

Ask your film supplier for the operating instructions.

The pallet must be lifted so that the four corners are accessible: the purpose of this is to allow the film to be shrunk under the pallet and so ensure very strong cohesion between the pallet and the load it supports. You will find an accessory in the RIPACK product range that is designed specially to keep pallets lifted from the ground: the CALPACK (contact your dealer).

Slide the shrink cover, which must be about 5% wider than your pallet and sufficiently long to be able to be shrunk under the pallet (H plus 200 mm).

Ignite your RIPACK 2500 as explained in the chapter «Operation».

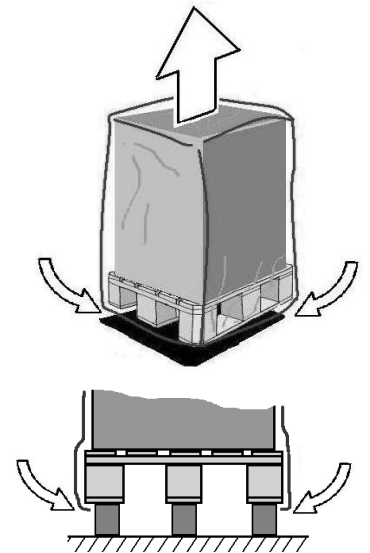

SHRINK-WRAPPING RECOMMENDATIONS

(in the absence of instructions provided by the film manufacturer)

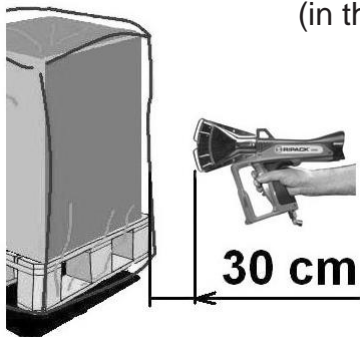

Remain at a distance of at least about 30 centimeters from the film and start shrink-wrapping the lower part of the four sides so the pallet is shrink-wrapped underneath. Make sure you point the air flow perpendicularly along the sides of the pallet.

Apply the heat in a continuous movement and at a constant speed.

NEVER STAY ON THE SAME SPOT

The various films react differently, so you must observe the reaction and adapt your speed and movement and/or the distance between the nozzle and the film accordingly.

You can also adjust the power of the RIPACK 2500 with the adjustable SECURIPACK controls.

Once the lower part of the pallet has been shrink-wrapped, continue the operation for each side and move from top to bottom to cover the entire height.

Once the 4 sides have been shrink-wrapped, you can do the top by applying the hot air to the top of the pallet.

CAUTION: The film is already stretched along the sides so you should apply less heat on the top in order to prevent the cover from being damaged.

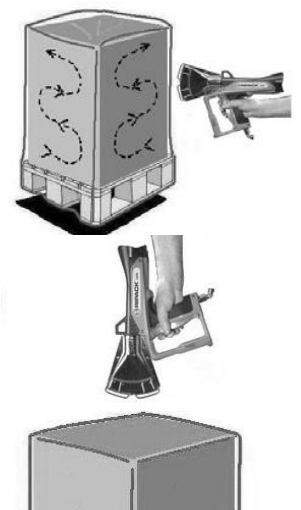

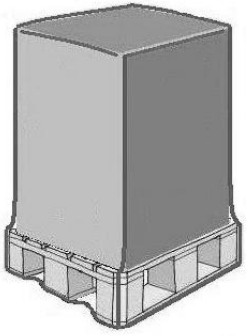

When you have stopped applying heat with the gun, the plastic film, because of its make-up, will continue to shrink for some time. This time will vary depending on the quality, the thickness and the type of load that has been wrapped. It is recommended therefore that you wait until the cover has cooled off and everything is tight before moving the pallet.

After cooling and before storage, always check that the cover and the wrapped goods are in good condition.

**CHECK CAREFULLY FOR AT LEAST 2 HOURS
AFTER SHRINK-WRAPPING.**

PACKAGING

All kinds of objects with irregular shapes can also be packaged using shrink-wrap film.

To obtain a good film joint, you need to provide a minimum overlap of 30 cm.

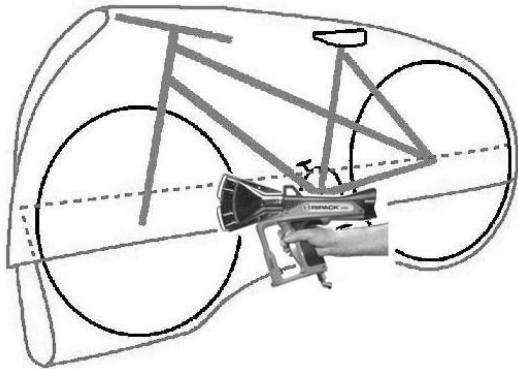
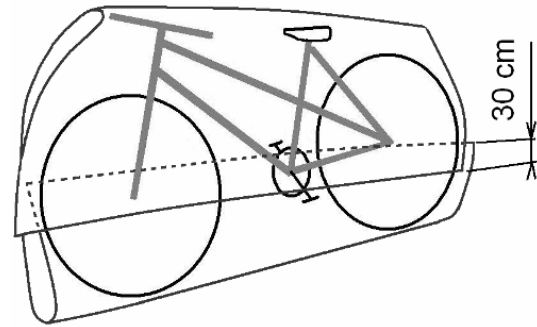







Start by heating the film in a continuous movement and then put pressure on this part to connect the two parts together.

Once the joint has been made, continue the shrink-wrapping by holding the appliance at least 30 cm from the film. When doing this, be sure to follow the recommendations for shrink-wrapping.

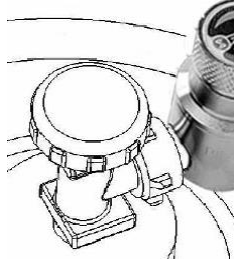
MAINTENANCE

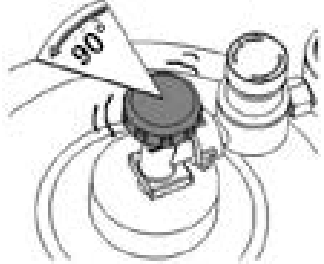
MALFUNCTION DIAGNOSIS

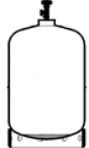
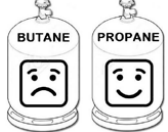
NO GAS COMING OUT OF YOUR RIPACK 2500

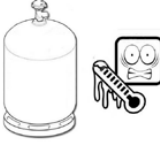
<p>CYLINDER VALVE CLOSED</p>		<p>OPEN THE FAUCET BY 90°</p> 
<p>Too high flow rate (The internal safety of the gas cylinder can shut off the flow if the valve is opened too much).</p> 	<p>Close the valve</p>	<p>OPEN THE FAUCET BY 90°</p> 
<p>REGULATOR IMPOSSIBLE TO PRIME</p> <p>1..2..3 s </p>  <p>Note: the red button cuts off the gas supply below a pressure that is too low for the operation of the Ripack 2500.</p>	 <p>Change the bottle</p>	
 <p>The regulator Only works With propane gas</p>		
 <p>BOUTEILLE GIVREE</p> <p>Continuous use causes the Bottle to frost Provide a replacement cylinder While the gas warms up.</p>		
 <p>TEMPERATURE BOUTEILLE</p> <p>The outside temperature Is low Store the bottles in a Temperate room.</p>		

Note: the pressure of the gas in a cylinder is proportional to the temperature of the gas.

MALFUNCTION DIAGNOSIS : DIFFICULTIES IN IGNITION OF YOUR RIPACK 2100

PIEZO USED



THE PIEZO LOSES ITS
ELECTRICAL PROPERTIES
WITH EACH SOLICITATION.

SPARE PIEZO REFERENCE:
131003

1



2



3



MALFUNCTION DIAGNOSIS : DIFFICULTIES IN IGNITION OF YOUR BURNER

THE GAS FLOW RATE IS
ABNORMALLY REDUCED
(short and weak flame)
The ignition is not easy to do.

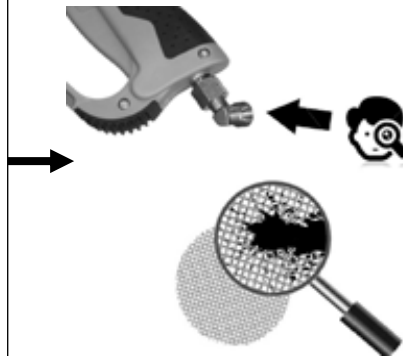

The swivel is equipped with a
grid filter .
This can be blocked by the
pollution of a gas cylinder:
Remove the filter with a
pointed needle.
Reassemble after cleaning.

POLLUTED COMBUSTION
NOZZLE

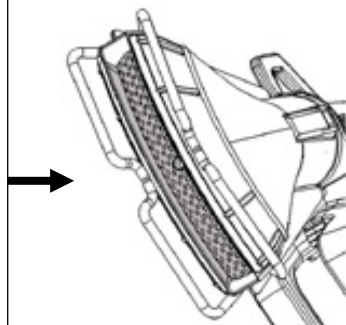

Clean the grid.
Thoroughly clean the spark plug
housing which mainly generates
the ignition of the flame.
We recommend the use of a
compressed air blower.

MALFUNCTION DIAGNOSIS

NO GAS CUT-OFF AFTER RELEASING THE TRIGGER

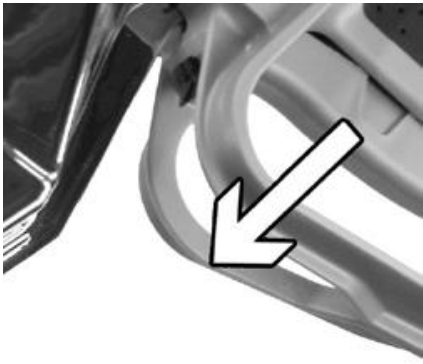

When the trigger is released, the combustion nozzle should shut off instantly.

Otherwise : Open the trigger.

Lubricate the piston of the dust-contaminated valve.
In case of repeated blockage, have the valve changed by your authorized Ripack dealer .



CHECKING THE SECURIPACK

The correct functioning of the safety mechanism must be checked for hose rupture (incorporated in the SECURIPACK) at least every 500 hours or every three months. This is to be performed as follows:

- Go outside, a long way from any flame source, sparks and any objects that ignite
- Apply pressure to the appliance. With the wrench supplied, loosen the connecting nut of the hose and unscrew completely: the gas supply will now be cut off automatically.

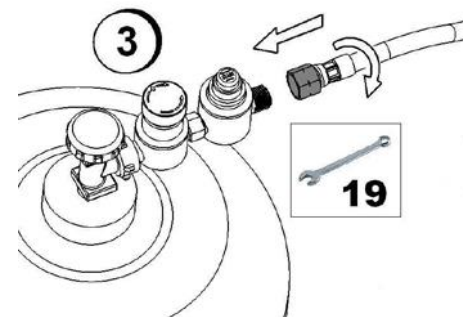

CHECKING THE RIPACK 2500

DAILY before starting to work:

1. Check the condition of the hose along its whole length and at the fittings.

We recommend that you replace the hose in the following cases:

- When a visual inspection has revealed damage (cuts), even if the damage is superficial.
- Every 3 years if used intensively.
- At the latest 5 years after first use
- **Note: The date on the hose is the manufacture date.**

Only use a replacement hose supplied by RIPACK with its original fittings!

2. Verify that the gas supply is shut off by releasing the trigger.

See : NO GAS LOSS on previous page.

FIND OUR TUTORIALS ON THE WEBSITE
<https://ripack.com/en/tutorials/ripack-2500/>



WARRANTY

The products delivered by RIPACK® (SEFMAT Group) are covered by a contractual warranty for a period of two (2) years from the date of delivery, covering any latent defect resulting from a defect in material, design or manufacture affecting the Ripack 2500 gun and rendering it unfit for use.

This contractual guarantee applies only to the first user of the Ripack 2500 gun after registration of the product on the RIPACK® website at the following address <https://ripack.com/en/register-a-product/>. For the application of this warranty, the Ripack 2500 gun must be registered within three (3) months following the purchase of the product.

The purpose of this warranty is to ensure the proper functioning of the Ripack gun 2500 having suffered an internal breakdown. In order to assert its rights, the user of the Ripack 2500 pistol must, under penalty of forfeiture of any action, take the following measures related thereto, inform RIPACK in writing at info@sefmat.com, the existence of defects within a maximum of seven (7) days from the date of their discovery. This warranty covers the cost of repairing the Ripack 2500 (parts, labor and return postage, the outward postage stays at the customer) or its replacement (in the case of the impossibility of replacing it). It does not entitle you to any compensation in kind or in cash.

The replacement of defective Products or parts will not extend the duration of the above-mentioned warranty.

The warranty forms an inseparable whole with the Ripack 2500 gun sold by SEFMAT or its authorized reseller. The Ripack 2500 gun may not be sold or resold altered, transformed or modified. Validation by our approved partners or by our manufacturing site will only be possible if all the parts that make up your heat shrink gun (shrink gun, swivel, hose and regulator) are returned to us. Without the complete return, we will not be able to validate the warranty.

Our two (2) year contractual warranty does not apply in cases of force majeure and does not cover :

- Deterioration, normal wear and tear of the product and in particular the following wearing parts: piezo igniter #131003, spark plug #132054, gas hose #250023.
- Accessories added after the purchase of the product (if applicable, a specific warranty related to the accessory concerned will apply)
- Defects due to damage, an accident or a fortuitous event or an accident resulting for example from a shock or a fall.
- Abnormal use, misuse or use under conditions different from those for which the product was manufactured, in particular in the event of failure to comply with the conditions prescribed in the RIPACK® instructions for use.
- Transformations of the product and in particular the modifications made or the addition of parts not coming from the manufacturer.
- Failure to regularly maintain the product as described on page 21 of the RIPACK user manual, negligence or failure to monitor the product on the part of the purchasing customer.
- Pre-existing repair of the product not provided by RIPACK® or an authorized RIPACK reseller.
- Products no longer bearing the label or identification number or products with a changed identification number.

RIPACK® 2500

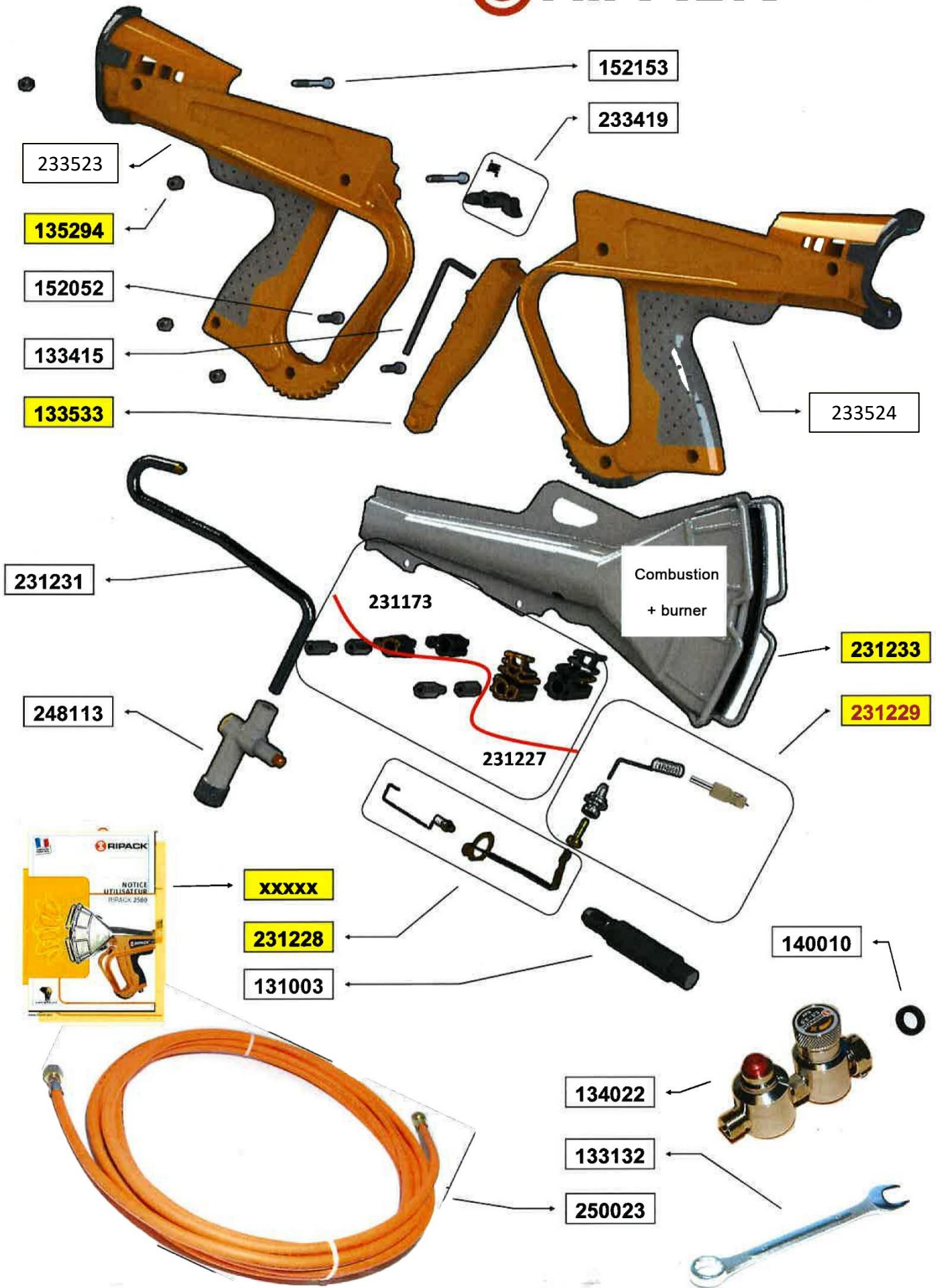

**CHECK YOUR PRESSURE
REGULATOR NUMBER**



NF



134022

UNI



134023

DIN



134024

USBS



134025

SPARE PARTS LIST

Art. Code	Description
131003	Piezo igniter (for heat gun without extension wand)
133132	Wrench 19
133415	Allen key 3
233523	Half-handle - right
233524	Half-handle - left
133533	Trigger
135294	Spacer for handle
140010	Flat Seal for Regulator NF
144053	User's Guide RIPACK 2500
148043	Swivel connector
152052	Screw CHc M 4 x 16
152153	Screw CHc M4x35
231173	Bumpers set
231225	Complete set combustion nozzle (spark plug + contact + spacers)
231231	Aluminum tube and jet / Ripack 2500
233419	Pawl & Spring - Trigger lock
248113	Gas tap
250023	Rubber Hose, 8 m with connections 3/8L (int Ø 6)



**DÉCLARATION DE CONFORMITÉ CE
EC- DECLARATION OF CONFORMITY
CE - KONFORMITÄTSERKLÄRUNG**

Le fabricant soussigné :
The manufacturer undersigned :
Der unterzeichnete Hersteller:

SEFMAT S.A.S, 7 RUE DE BETNOMS, 33185 LE HAILLAN, FRANCE

Déclare que l'appareil :
Hereby declares that the appliance :
Erklärt hiermit, dass das Gerät :

RIPACK 2500

destiné à la production d'une flamme produite par la combustion de gaz
designed to produce a flame produced by the combustion of gas
zue Erzeugung einer durch Verbrennung von Gas erzeugten Flamme bestimmt ist,

est conforme aux dispositions du Règlement (UE) 2016/426 du 9 mars 2016 concernant les appareils brûlant des combustibles gazeux.

is in accordance with the Regulation (EU) 2016/426 of 9 March 2016 on appliances burning gaseous fuels.

den Anforderungen der Verordnung (EU) 2016/426 vom 9. März 2016 über Geräte zur Verbrennung gasförmiger Brennstoffe entspricht.

Cette conformité est confirmée par le laboratoire DVGW CERT sous le numéro DG-2418BR0325.

This conformity is confirmed by the DVGW CERT laboratory under number DG-2418BR0325.

Diese Konformität ist vom DVGW-CERT-Labor unter der Nummer DG-2418BR0325 bestätigt.

Fait au Haillan, le 6 Mai 2024
Le Haillan, May 6th, 2024
Le Haillan, 6. Mai 2024

Le Président
President
Vorstandsvorsitzender

CERTIFICATIONS INTERNATIONALES
WORLD CERTIFICATIONS



RIPACK® ACCESSORIES

GAS CYLINDER CART

The Ripack gas bottle trolley is the essential accessory to move your gas cylinders easily and safely and to ensure the longevity of your equipment.

Its design allows a great support, and the mast assists you in the handling and protection of the hose. The new carts were thought to be a real workstation. They are designed to be a real workstation, which is why they are equipped with a tool bag, allowing you to carry your tools easily. The 936+ and 932 carts are also equipped with a shelf, as well as a magnetic device.



GAS HOSE REEL WINDER

Heavy duty construction for industrial application : corrosion resistant powder coated steel, four-direction non-sag rollers reducing hose wear abrasion.

Possible mounting on wall, ceiling on floor.
Provided with swiveling support for a greater ease of work.
Adjustable guiding arm for horizontal or vertical hose release.



TURBOPACK SHRINK COLUMN

The Turbopack is a mobile heating column, loaded on an easily movable trolley.

Its unique design allows for a surge of hot air flow for unmatched efficiency, even on thick films. 50 seconds are enough to heat-shrink a pallet (Euro type) up to 3.2 meters.

Adapting to your load is very simple, a series of shutoff valves allow you to consume the right amount of gas and the heat reflector (visor) plate (optional) can be adjusted with a simple gesture with the help of a balancer. No need for complex programming, tedious handling or long and costly training.



RIPACK ACCESSORIES

MULTICOVER FILM SEALERS

The Multicover sealers allow to make pallet covers and bags from rolls of shrink-film when required and in any size.

Make savings by avoiding useless stock of various heights and sizes.



MULTICOVER 955
Ripack Heat Gun Sealing



MULTICOVER 960
Electrical impulse sealing



2nd reel in option

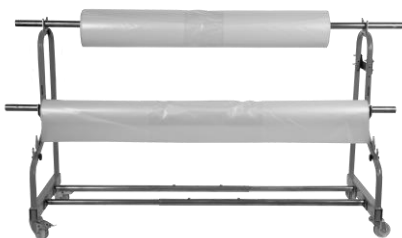

MULTICOVER 935

CALPACK PALLET RAISER

Quick and easy to set up, the Calpack allows the film to shrink under the pallet. The load is thus perfectly stabilized with the pallet. Calpack can be used as well with a pallet-truck or a fork-lift.



Ripack is for the
PROFESSIONALS,
Use **PROPANE** gas.