



RIPACK®

RIPAGREEN®

RIPACKSUPPLIES®

Gas Hose Reel Winder With Swivelling Support

Réf. : 334081

User's Guide



EXPLODED DRAWING	2
INSTALLATION	3
OPERATION	3
MAINTENANCE	4
REPLACEMENT PARTS	5
GUARANTEE	6
DECLARATION OF EC CONFORMITY	7

*

EXPLODED DRAWING

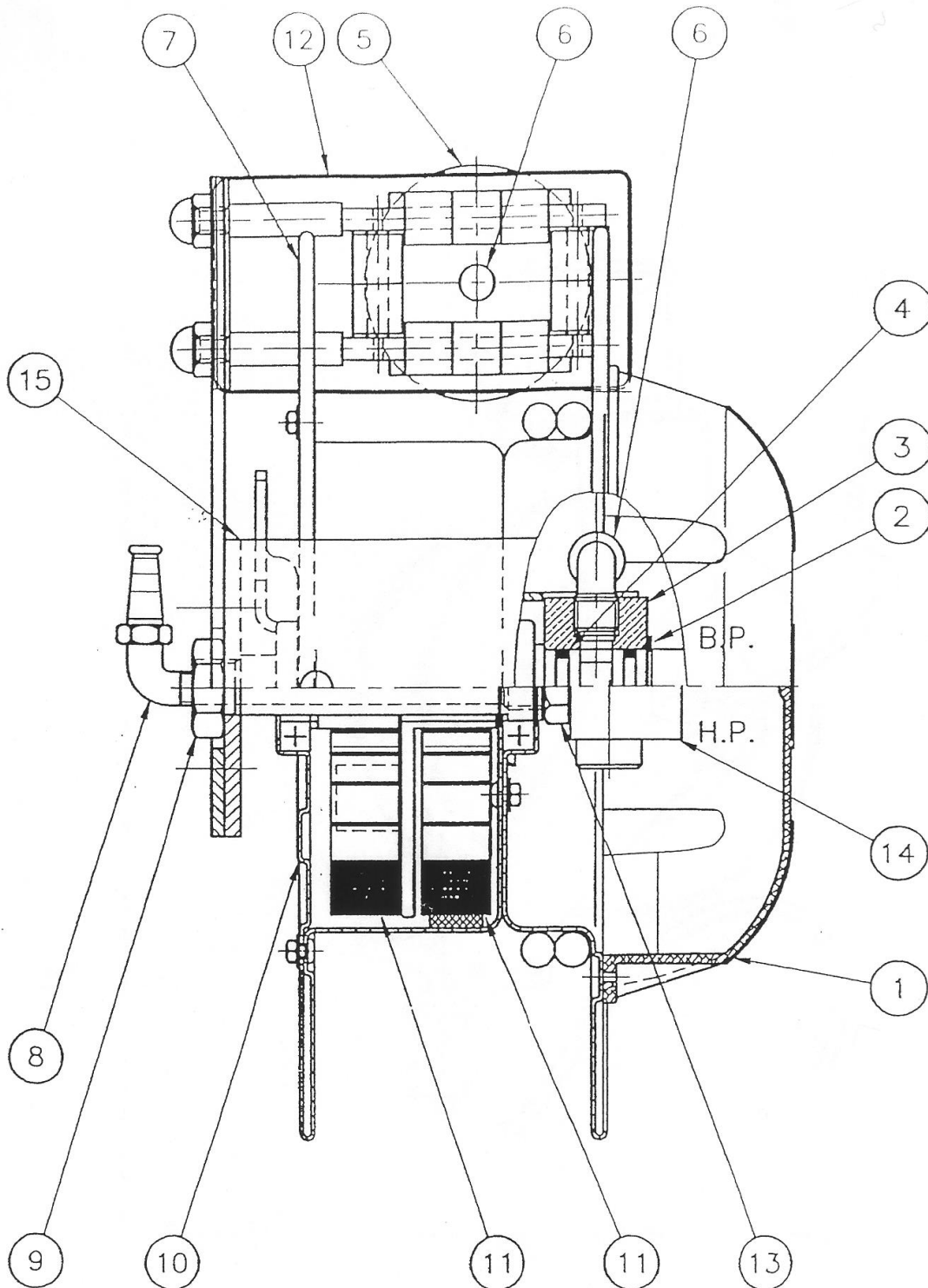

Vue avec 2 ressorts en série

INSTALLATION

Supply

The reel is supplied to be mounted on the wall or the ceiling.

The ratchet lock can work in these both positions.

In option the open model can be equipped with a rotating pivot for the installation on the wall only.

Mounting

- At about 8' from the ground in case of installation on the wall
- According to the hose length in case of overhead installation
- The reel is mounted by bolting the base to any flat surface which is structurally sound enough to support it and the forces of winding and unwinding the hose.
- Provide for 2 M12 screws.
- The reel should be oriented so that hose extends perpendicular to the rotation of the spool.
- Connect the fluid inlet on the casing or the frame side. This connection must be flexible.

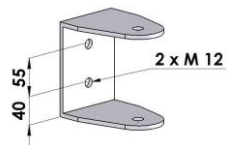

Operational warnings

- Verify that the operating pressure does not exceed 58 PSI.
- Verify that there is a pressure regulator upstream and that it is working properly to avoid accidental bursting of the hose.

OPERATION

Operation of the ratchet

When extending the hose, the pawl goes over a cog wheel, generating a characteristic noise.

In that position, the hose can be released, the ratchet is engaged.

To disengage it, extend the hose until it is fully winded.

Never loosen the hose out of the cog wheel.

MAINTENANCE

Swivel joint maintenance

The connection of a hose reel is to be checked every 1000 hours.

Replace the O-rings as necessary.

In case of abnormal pressure drop, check for any leak upstream or downstream the reel, and inspect the hose, the connection and the o-rings.

Before any servicing:

1. Shut-off fluid inlet.
2. Remove the cover pos. 1.

O-rings Replacement (on low pressure connection)

3. Remove circlip pos. 2.
 4. Remove the hub pos. 3 by translating it.
 5. Remove the 2 o-rings pos 4.
 6. Clean the shaft and place the 2 new o-rings without scratching them.
 7. Slightly lubricate with a lithium lubricant.
 8. Clean and re-assemble the hub pos. 3.
 9. Re-assemble circlip pos. 2.
 10. Re-assemble the cover pos. 1.
- Follow steps 16 through 19.

Swivel connector replacement (high pressure)

3. Remove the hose pos. 6.
 4. Remove the swivel connector pos. 14 by unscrewing shaft pos. 13.
 5. Replace with a new connector.
 6. Reconnect the hose pos. 6.
 7. Re-assemble the cover pos. 1.
- Follow steps 16 through 19.

Hose replacement.

3. Remove the hose clamp pos. 5 by holding the wheel pos. 7, and let the reel rotate by holding it until full disengaging of the springs.
 4. Disconnect the hose pos. 6 from the swivel connector pos. 3 and locate the winding direction.
 5. Wind the new hose in the same direction as the old one.
 6. Reconnect the hose pos. 6.
 7. Re-assemble the cover pos. 1.
- Follow steps 16 through 19.

Spring replacement.

3. Disconnect the fluid hose.
4. Remove elbow pos. 8 (if present).
5. Remove the hose clamp pos. 5 by holding the wheel pos. 7, and let the reel rotate by holding it until full disengaging of the springs.
6. Remove the bolt pos. 9.
7. Remove the spool pos. 7 from frame pos. 15.

8. Remove the flange pos. 10 of the spool pos. 7.
9. Remove the spring(s) pos. 11 pre-cautiously and locate the hooking direction.
10. Place the new spring(s) in the same direction as the old ones.
11. Re-assemble and tighten the flange pos. 10 of the spool pos. 7.
12. Re-assemble the spool on the frame pos. 15.
13. Retighten bolt pos. 9.
14. Re-assemble elbow pos. 8 and ensure the threading tightness (with oiltight Loctite, paste, etc...).
15. Reconnect the fluid hose.
16. Cycle the spring(s) pos. 11 by rotating the spool pos. 7 in the unwinding direction as keeping the hose fully wound on the spool.
17. Get the hose out through the roller guide pos. 12.
18. Re-assemble the ball stop pos. 5 on the hose pos. 6.
19. Open fluid inlet.

REPLACEMENT PARTS

(Other parts on request – the serial number of the reel is required when ordering replacement parts)

Return spring	Ref. 43R45015	1
Ratchet spring	Ref. 40170016	1
Ratchet	Ref. 33R60001	1
Pawl	Ref. 43C52006	1
Hose Diam. 15 m long with connections 3/8L	Ref. 250099	1
Hose Diam. 2 m long with connections 3/8L	Ref. 250090	1
O-rings (low pressure)	R10 Type for 1/8" or 1/4"	2
Connection assembly (high pressure)	1/4" or 3/8" Type	1

GUARANTEE

Your HOSE WINDER has been manufactured with the greatest care using quality materials. Numerous tests and inspections were carried out during production.

Every component meets the requirements of strict specifications in order to guarantee performance and adaptability.

For all maintenance work and spare parts, your RIPACK dealer ensures the supply of spare parts in accordance with the RIPACK requirements, guarantee of quality and of safety.

RIPACK WARRANTY:

Warranty of Operation for one year under the following conditions:

- that the appliance has been used in compliance with the user's guide;
- that the appliance has not been disassembled except for the procedures described in the user's guide;
- that the appliance is physically intact (for example: flanges, arm and support, etc...).

This warranty does not apply to the following replacement parts:

- Hose,
- Ratchet,

All replacement parts must be original RIPACK spare parts. The manufacturer shall not be held responsible and shall not be liable for any claims in the event that the aforementioned warnings and instructions are not respected.

The company RIPACK shall not be held responsible for accidents involving persons or goods which arise from the incorrect use of the appliance or from using it for an application which is not specifically mentioned in the user's guide. All disputes shall be governed by the courts of Bordeaux - France. No other place of jurisdiction shall be accepted.

The use and the resale of the HOSE WINDER imply the acceptance of the aforementioned terms and conditions.

IN THE EVENT OF A WARRANTY CLAIM, PLEASE ATTACH A COPY OF YOUR SUPPLIER'S INVOICE.

DECLARATION OF EC CONFORMITY

The manufacturer, undersigned:

Sté SEFMAT - Rue de Betnoms – 33187 LE HAILLAN CEDEX – France

Hereby declares that the equipment described hereafter:

Hose reel 334081 Type 3

Is in conformity:

- To the prescriptions of appendix I of the European directive EN 89/392 modified by EN 91/364
- To the European norm EN 746-2.

Made at: LE HAILLAN, June 6, 2019

Name and position:

François Clément
Responsable Ligne Produits

Signature:



7rue de Betnoms, 33185 Le Haillan - France
Tél +33 (0)556 34 35 18 Fax. +33 (0)556 34 80 82
e-mail : info@ripack.com Web site : www.ripack.com