



GROUPE SEFMAT

RIPACK®

USER'S GUIDE

MULTICOVER 960



YOUR PROTECTION
BY EXCELLENCE

REGISTER YOUR PRODUCT
ONLINE WARRANTY CONTRACT
RIPACK.COM/EN/REGISTER-A-PRODUCT



SOMMAIRE

GARANTUEE.....	3
WARNINGS.....	3
TECHNICAL DATA.....	4
ASSEMBLY.....	5
INSTRUCTIONS OF USE.....	6
MAINTENANCE AND REPAIR.....	7
EXPLODED VIEW	9
SPARE PARTS LIST.....	11

GARANTIE

MULTICOVER GUARANTEES ®

TOTAL GUARANTEE against any faulty manufacture on a new appliance that has not been subjected to any dismantling or modification, used in accordance with this guide, and not having been subjected to extended usage. The total guarantee covers the exchange only of any recognized defective part(s).

OPERATIONAL GUARANTEE of one year, provided that:

- The appliance has been used in accordance with this guide;
- The appliance has not suffered from any dismantling other than those provided for in this guide;
- The geometry of the appliance is intact.

This guarantee does not apply to the following wear and tear parts:

- Sealing wire
- Cutting blade
- Teflon tape

Any replacement part must be an original **MULTICOVER®** part. The manufacturer declines any and all liability and any claim in recourse in the event of non-compliance with the preceding instructions and provisions.

The Company Ripack cannot be held liable for accidents caused to people or property. In case of dispute, jurisdiction lies solely with the Courts of Bordeaux, FRANCE.

For any claim under the guarantee, please enclose the copy of the invoice from your supplier.

Your guarantee begins at the date of invoice from your supplier.

WARNINGS

TO BE READ CAREFULLY PRIOR TO ANY INITIAL USE

THIS APPLIANCE IS INTENDED **EXCLUSIVELY** FOR PROFESSIONAL USE.

IT IS ESSENTIAL THAT USERS OF THE **MULTICOVER®** MAKE THEMSELVES FAMILIAR WITH THIS GUIDE IN FULL AND THAT THEY BE TRAINED IN THE APPLICATIONS FOR ITS USE.

THIS GUIDE IS TO BE KEPT FOR FUTURE REFERENCE .

THE **MULTICOVER® 960** IS DESIGNED TO SEAL OR WELD PLASTIC SHRINK-FILM, I.E. A SEALING BY HEAT PROCESS.

MULTICOVER® 960 MUST BE USED ONLY INSIDE OF LOCATIONS DEVOID OF MOISTURE.

IN ORDER TO GUARANTEE THE DURABILITY OF YOUR EQUIPMENT, ALWAYS DISCONNECT THE POWER AFTER WORK .

TECHNICAL DATA

Sealing process	Adjustable electrical impulse
Manual cutting process	Cutter on sliding cart
Maximum sealing capacity	Thickness: 4 x 200 μ - Width: 1500 mm
Maximum acceptable reel	\varnothing 500 mm - width 1500 mm - 100 kg max per roll
Weight - Dimensions (LxWxH)	95 kg - 1970 x580x1430 mm
Power supply - Tension and welding Power	230 V (50/60 Hz) - 24 V . 0,5 KVA
Mobility	4 rubber casters \varnothing 100 mm 2 fix casters + 2 swivel casters with lock



ASSEMBLY

Le Multicover 960 is delivered assembled.

The electric box is supplied separate in a protective carton.

There is only to put it onto the appropriate support (photo 1) and connect it to the Multicover (photo 2) then to the mains supply (photo 3).

The Multicover is now ready for operation.



Photo 1



Photo 2



Photo 3

INSTRUCTIONS OF USE

Positioning the film

- Check that the Multicover is not connected during the film positioning operation.
- Place the reel of film on the support axle and hold tight the mandrel with the 2 tightening cones (photo 4).
- Pull the film under the anti-slip rod and between the sealing jaws (photo 5).

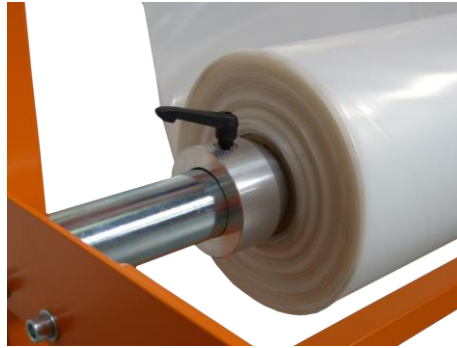

Photo 4



Photo 5

How to determine the sealing time

- Put the power on.
- Adjust the timer between 2 and 3 seconds (front of the electric control box: photo 6).
- Check that knife-carriage is at one end of the sealing jaw.
- Pull about 10 cm (5") of film.
- Lower the upper jaw with one of the two handles at the end of the bar down to the triggering of the timer.
- A tone indicates the sealing phase.
- After the tone, cut the film with the guided sliding knife (check the film is tight hold between the seal and the anti-slip rod). Press down the knife to release the blade (photo 7) and move it along the sealing bar.
- Raise up the welding jaw.
- Check the sturdiness of the seal (after 15 seconds cooling). If the films are not welded, slightly increase the sealing time. If the seal "goes through", reduce the sealing time.
- The sealing time will vary according to the film thickness and the work speed, but **the minimum time should always be selected**. During high-speed work, the sealing wire keeps residual heat; the sealing time can then be reduced consequently.



Photo 6

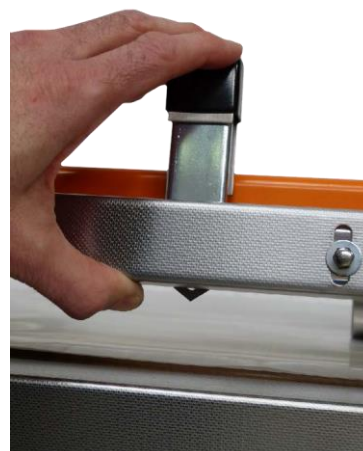

Photo 7

HOW TO MAKE COVERS

- Pull in the film or sleeve by 3 to 5 cm between the welding jaws.
- Lower one of the handles to achieve an automatic seal after having adjusted the sealing time according to the film thickness.
- Set the counter to zero with by lowering the red latch (photo 8). Open the sealing jaws and unroll the film to the required length.
- Close the sealing jaws and make a new seal that turns into the closure of the next bag. It is thus unnecessary to wait after the end of this sealing to cut and use the bag.
- Cut the film by actuating the guided knife and release the sleeve by pulling it slightly.
- The anti-return rollers tight hold the film in position for the next bags.

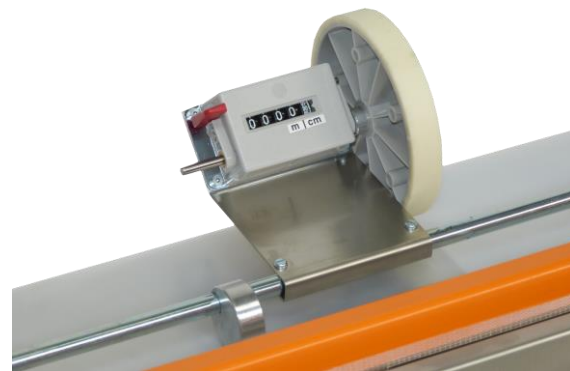

Photo 8

MAINTENANCE AND REPAIR

Before any maintenance, the machine should be DISCONNECTED

Maintenance

- Daily: clean the Teflon tapes with a cloth dampened with silicone.
- Monthly: check the wear of the cutting blades.

Replacement of the sealing wire

- Disconnect the Multicover.
- Unstick the Teflon tape.
- Unscrew the 4 screws (2 at each end) blocking the wire at the end of the sealing bar.
- Replace the worn wire by a new one. Tighten the wire with the screw at one end and by tightening it with pliers at the opposite end.
- Tighten the 2 other screws.

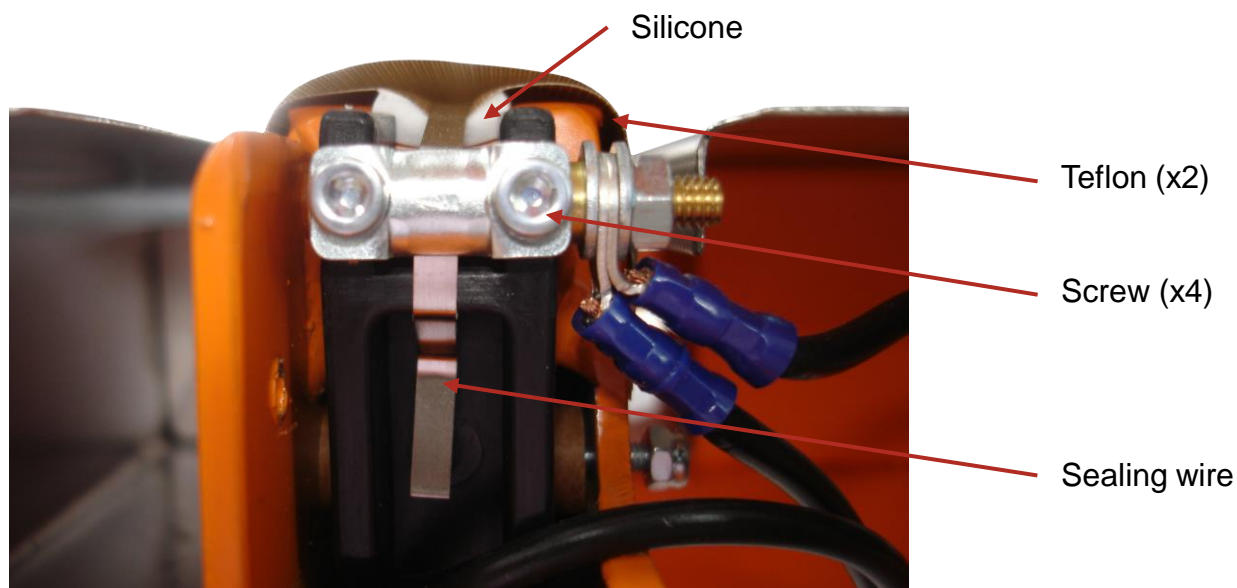

Replacement of the cutting blades

- As soon as cutting problems occur, change the cutting blades the following way:
- Loosen the nuts of the knife cart track (photos 9 and 10)
- Loosen the nut holding the blade and replace the blade
- Retighten the whole onto the Multicover.

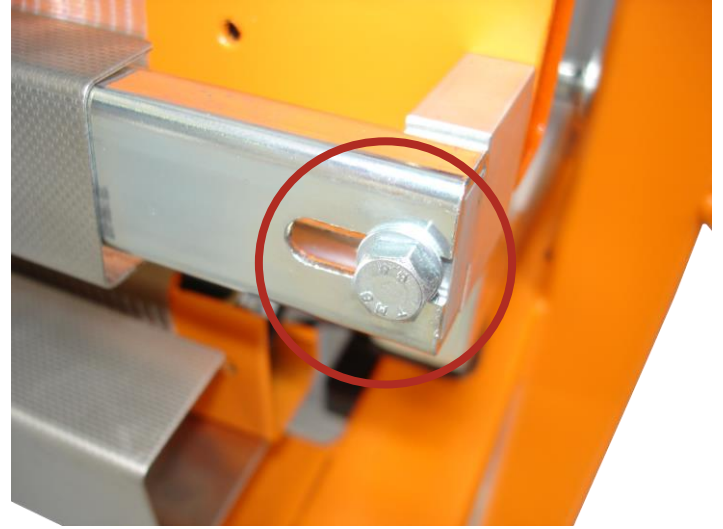
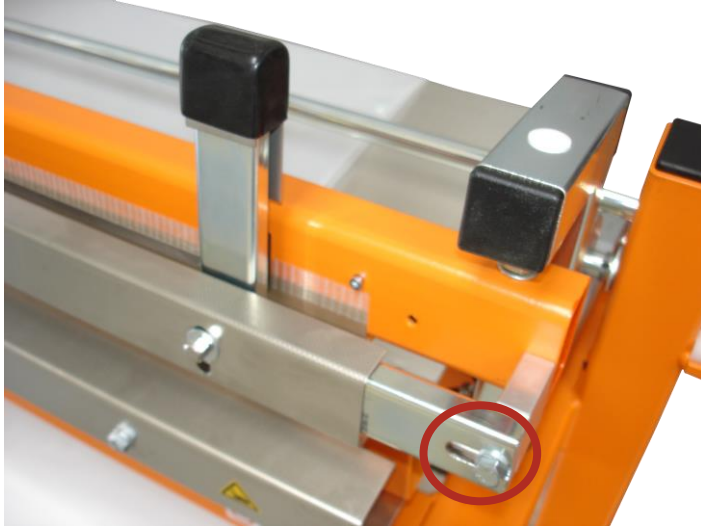

Comments

Burns marks on Teflon are normal after a certain period of use. An early wear is due to a wrong sealing time.



Please refer to the **regulations applicable in the country of use** concerning the conformity and use of the products and accessories offered in our Ripack® range. The use of Ripack® accessories, connections and spare parts is essential for the correct operation and guarantee of our products and for the safety of people and property.

EXPLODED VIEW

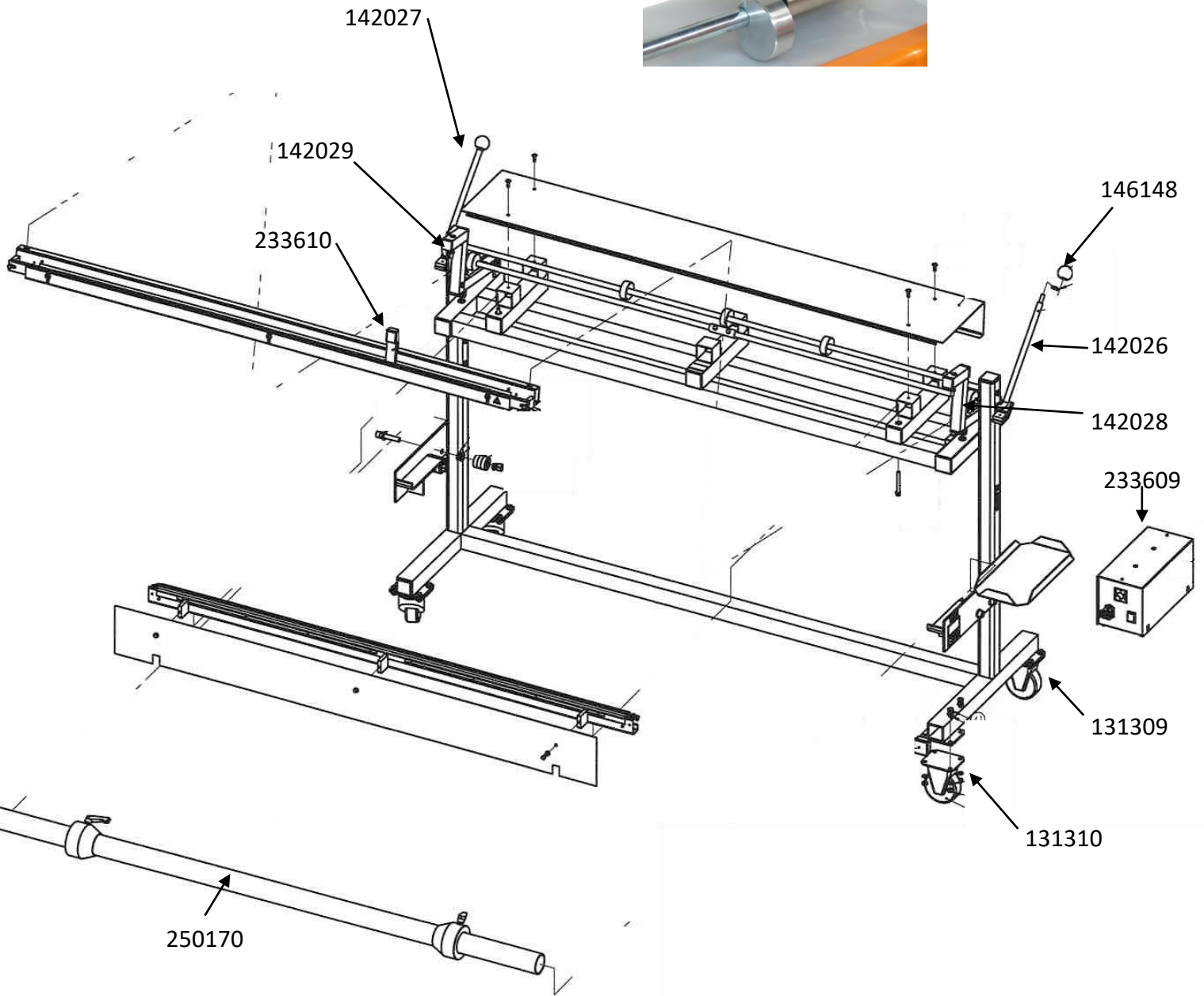
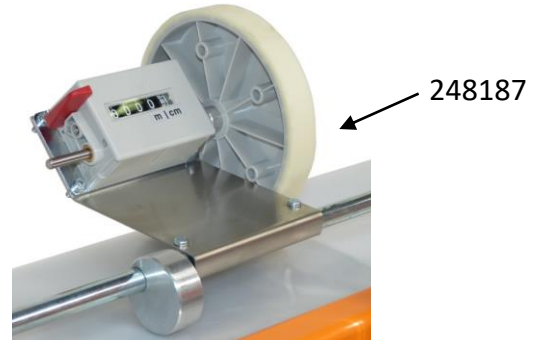

SEALING HEAD FOCUS

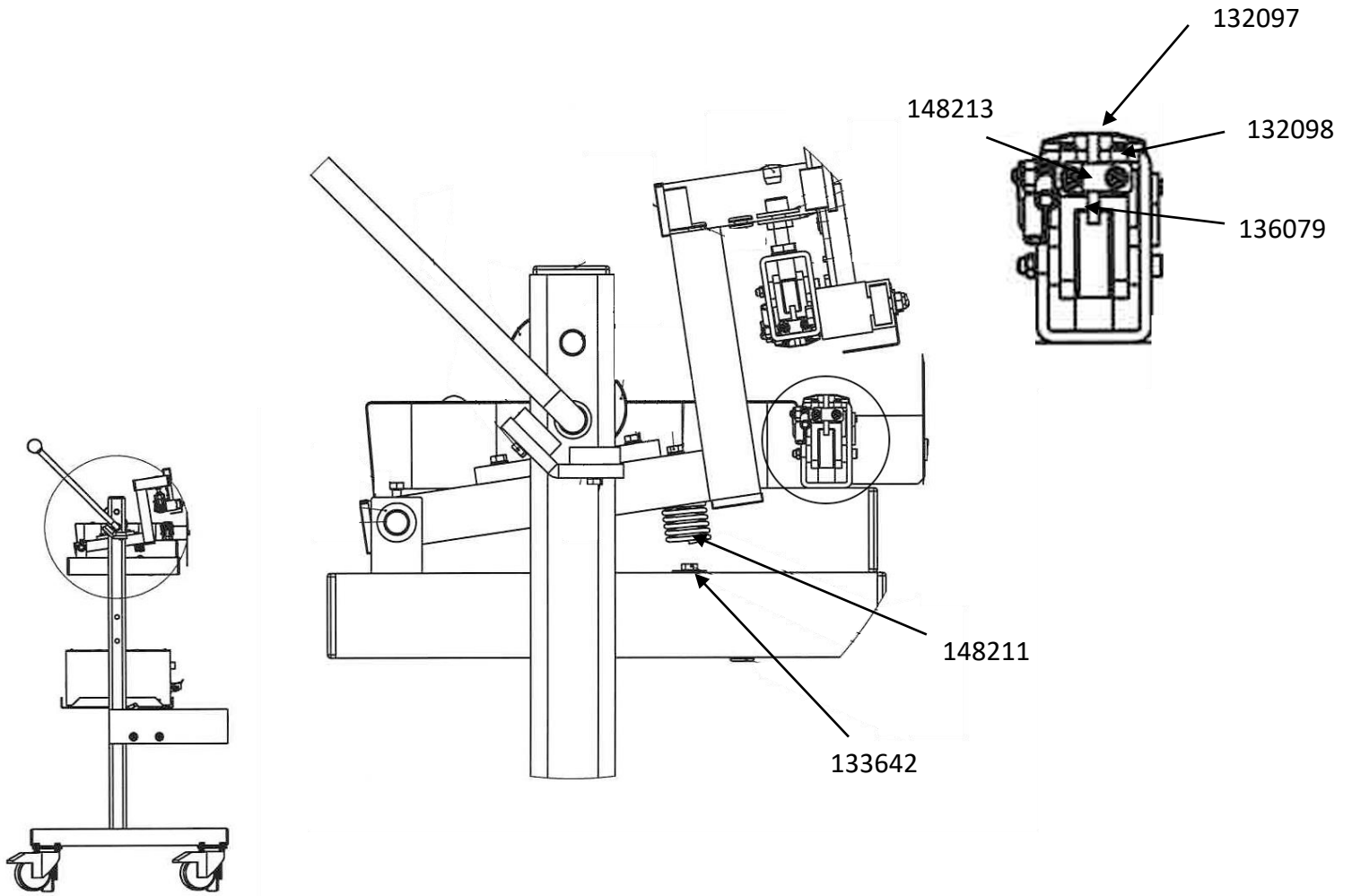

KIT reference 240090 = 2 x 132097 + 1 x 132098 + 1 x 136079

CUTTER CARRIAGE FOCUS (233610)

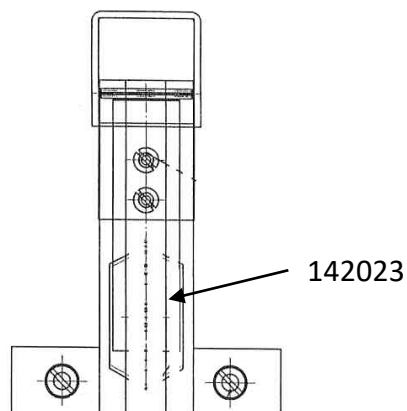

SPARE PARTS LIST

Item Code	Description
131309	Set of 2 wheels for M960 - no brake
131310	Set of 2 wheels for M960 - with brake
132097	Teflon adhesive tape, dimensions 80x1510x13/100mm (960)
132098	Insulated foam tape (960)
133642	Closing jaw contactor
136079	Sealing wire 3x015x1590 mm (960)
142023	Reversible cutting blade (960)
142026	Right handle / Multicover 960
142027	Left handle / Multicover 960
142028	Sealing Bar Support Right / Multicover 960
142029	Sealing Bar Support Left / Multicover 960
146148	Black knob for handle / Multicover 960
148211	Spring for handle / Multicover 960
148213	Spring for sealing bar tensioning
233609	220-240 Control box for Multicover 960
233610	Cutter carriage unit (960)
240090	1 bar sealing set: 2 Teflon tapes, 1 insulator, 1 sealing wires (960)
248187	Length Counter Wheel set
250170	Roll Holder Tube with cones and screws (960)
SAFEKNIFE_01	SAFEKNIFE_01 / Cutter de sécurité à bec (étui de 1)
SAFEKNIFE	SAFEKNIFE / Cutter de sécurité à bec (boite de 10)



DÉCLARATION DE CONFORMITÉ CE
EC- DECLARATION OF CONFORMITY

Le fabricant soussigné :
The manufacturer undersigned :

SEFMAT S.A.S, 7 RUE DE BETNOMS, 33185 LE HAILLAN, FRANCE

Déclare que l'appareil :
Hereby declares that the appliance :

MULTICOVER 960

correspond aux dispositions et aux normes harmonisées suivantes :
complies with the following regulations and harmonized standards :

Directive basse tension 2006/95/CE
Low voltage directive 2006/95/EC

Directive CEM 2004/108/CE
EMC directive 2004/108/EC

Directive RoHS 2002/95/CE
RoHS directive 2002/95/EC

Normes harmonisées EN ISO 12100-1
Harmonized standards EN ISO 12100-2

EN ISO 13857
EN 60204-1

EN 61000-6-1
EN 61000-6-3

Fait au Haillan, Mars 2012
Le Haillan, March 2012

Le Président
President

CERTIFICATIONS INTERNATIONALES
WORLD CERTIFICATIONS



